

KATALOG



Wszelkie prawa zastrzeżone.

Katalog szyb nie może być kopiowany w całości lub w części na rzecz firm lub osób trzecich bez zgody firmy Agrogilas. Katalog szyb może być wykorzystywany jedynie przez firmę do której został skierowany.

Katalog jest zestawieniem jedynie najbardziej popularnych szyb.

W przypadku nie odnalezienia poszukiwanej szyby prosimy o kontakt z nami:

tel. 501-290-251

063/272-04-17

e-mail: agroglas@agroglas.pl

Podkreślamy, iż jesteśmy w stanie dostarczyć szyby do niemal każdego modelu ciągnika.

Wykonujemy szyby płaskie, gięte, bezbarwne oraz kolorowe.

W naszej ofercie posiadamy także szyby do zachodnich marek ciągników.

Zapraszamy do współpracy

C – 330 Chojnów

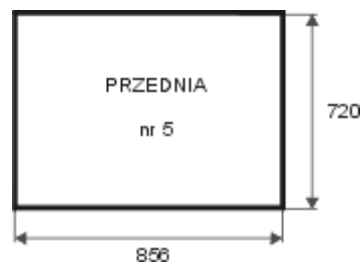
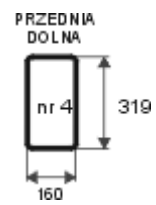
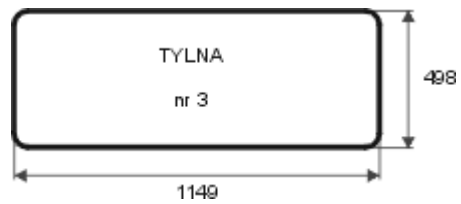
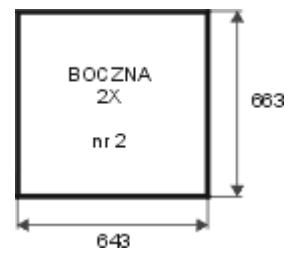
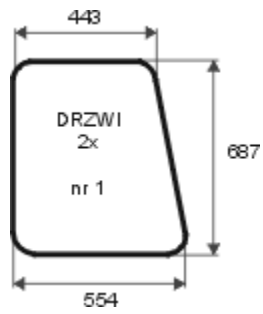

C-330 Chojnów

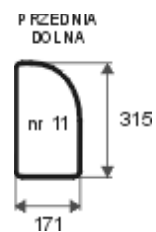
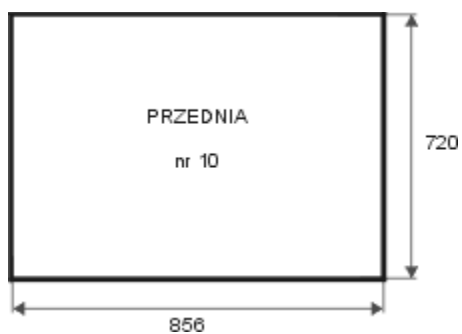
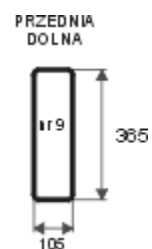
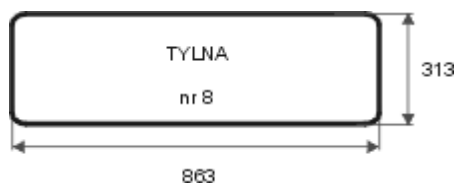
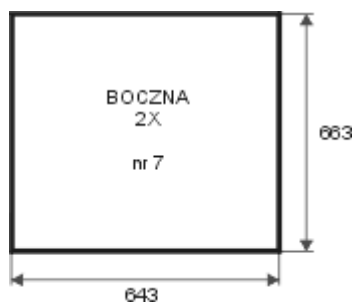
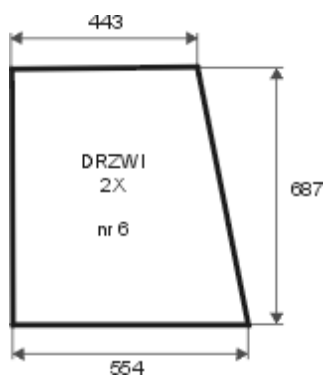

C – 330 Ciechanów

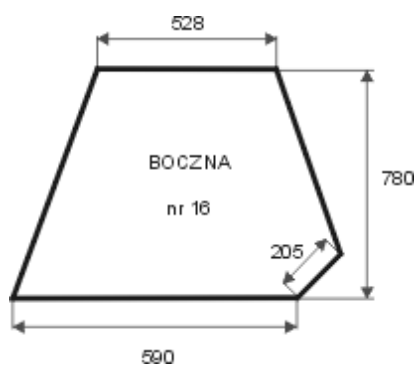
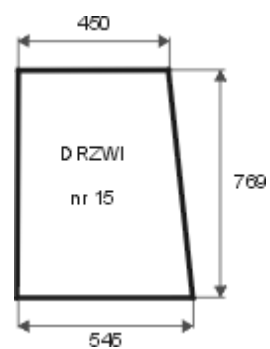
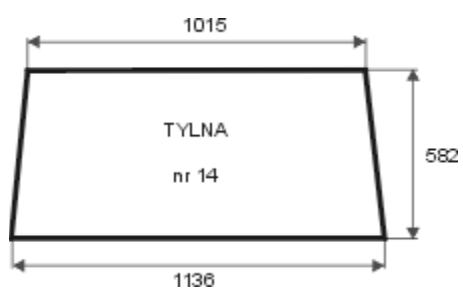
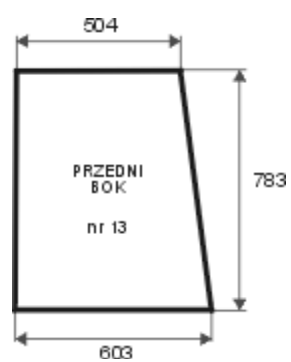
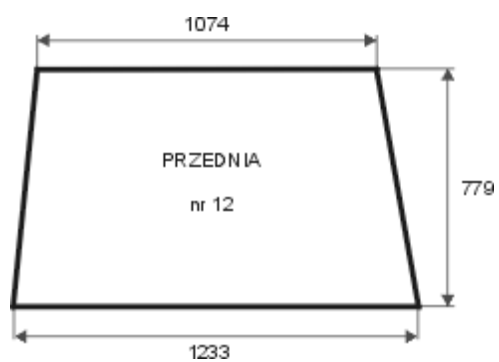

C-330 Ciechocin

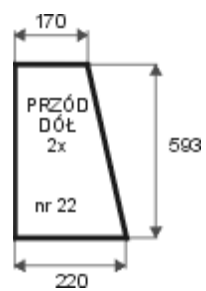
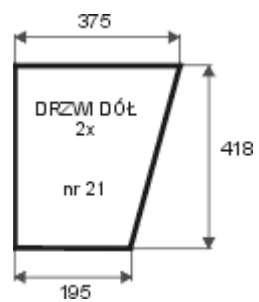
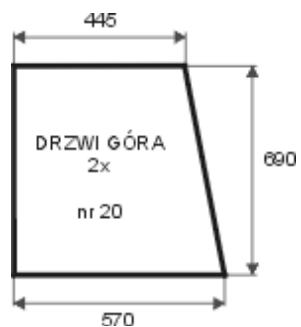
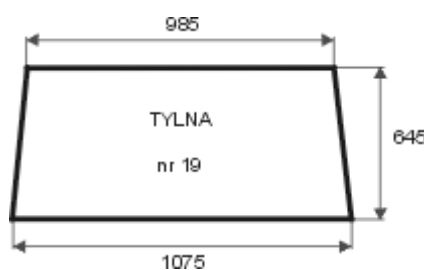
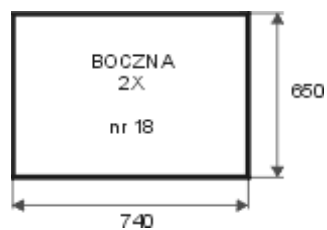
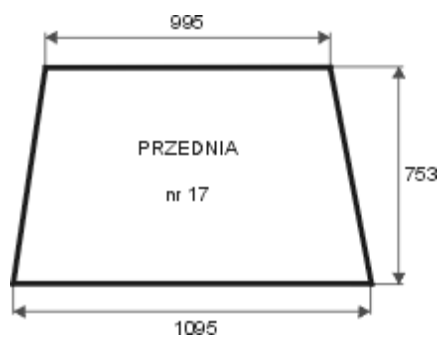

C – 330



Kabina produkowana w Krotoszynie

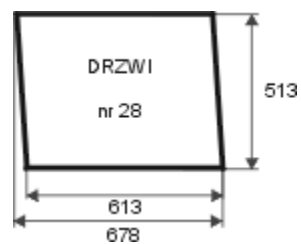
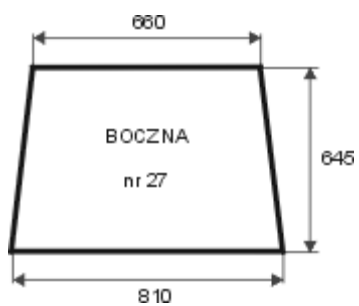
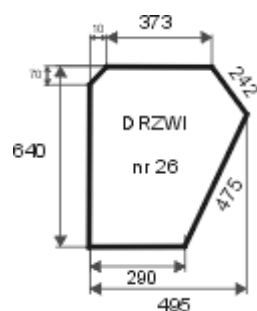
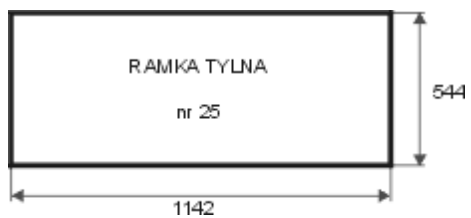
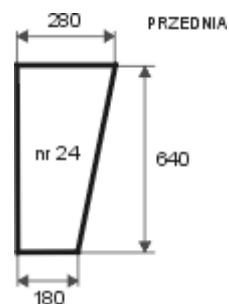
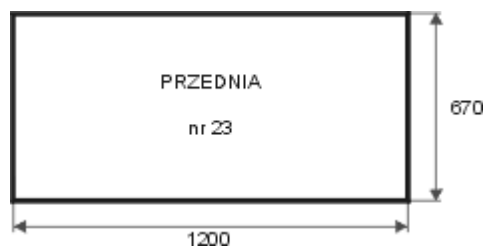

C-330 Kunów

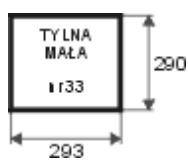
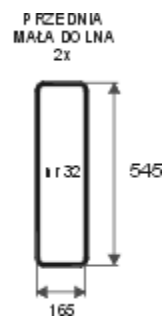
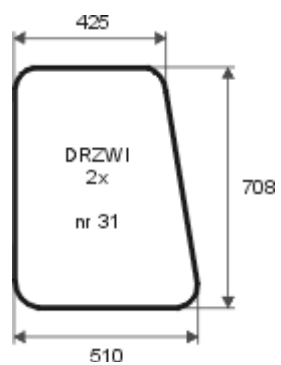
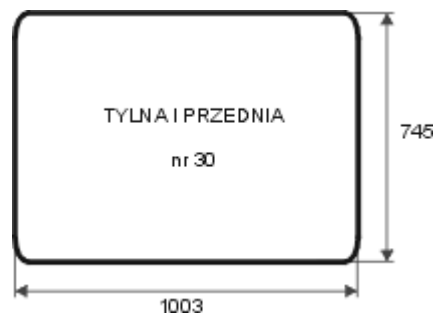

C – 330 *Kunów*

(nowy typ)

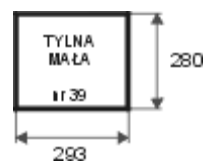
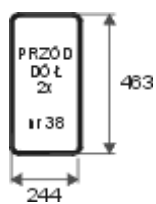
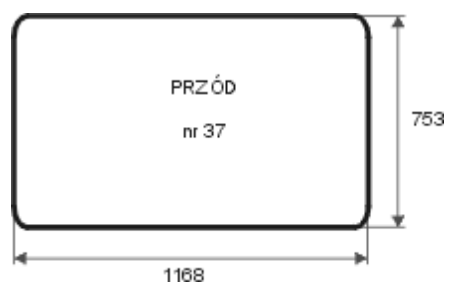
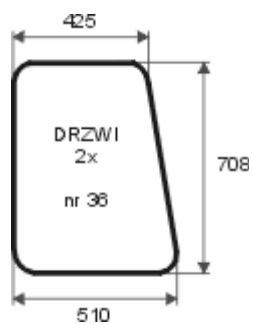
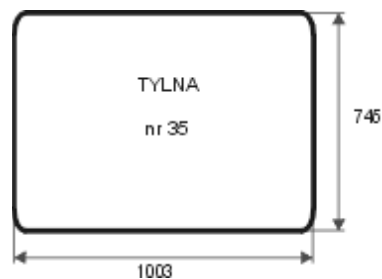

C – 330 Osiny

(nowy typ)

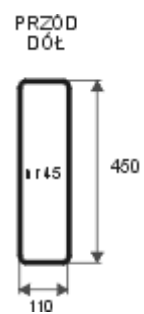
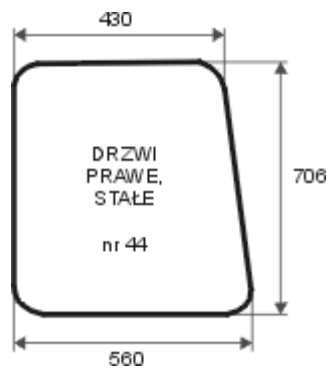
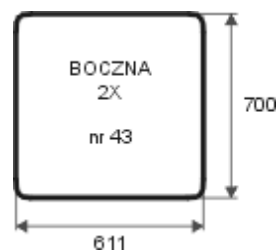
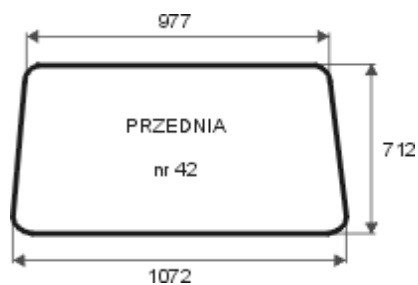
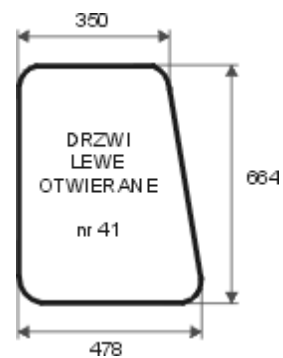
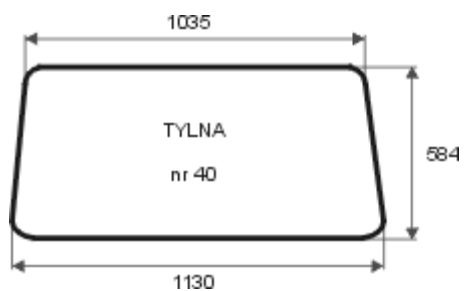

C – 330 Osiny

(ramki z rury kwadratowej)

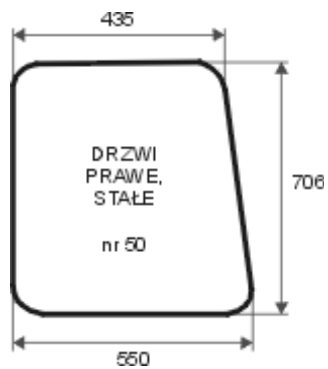
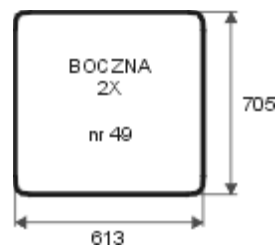
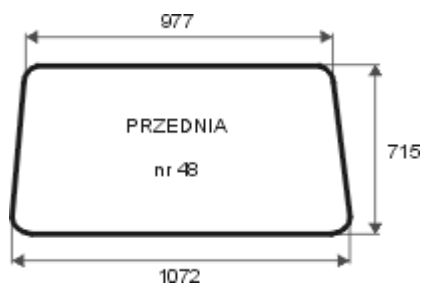
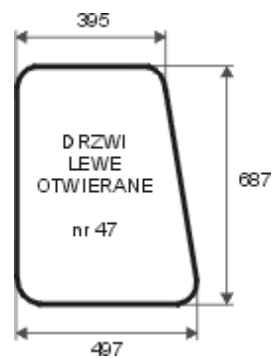
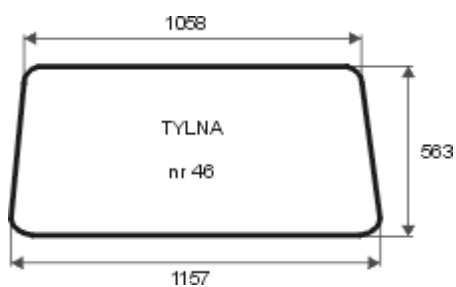

C-330 POM Zamość

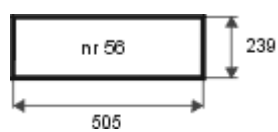
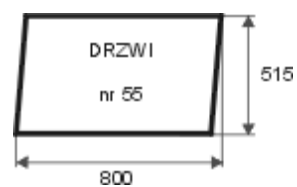
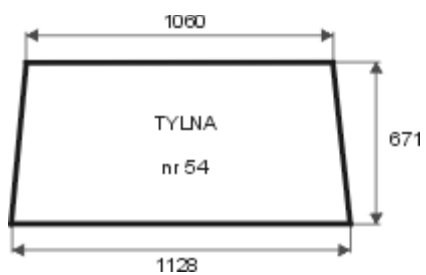
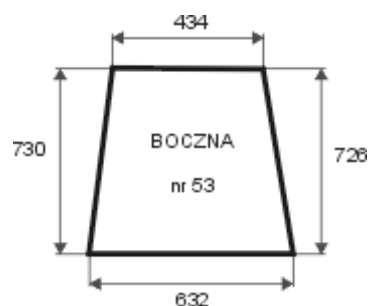
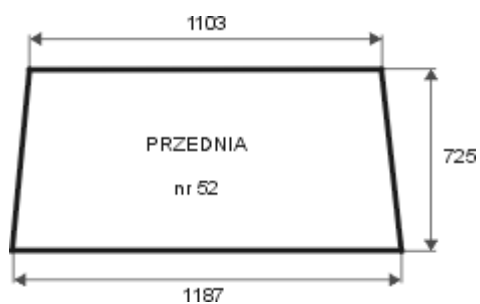

C – 330 Smolniki



Kabina firmy Koja Kabina polska do ciągnika T – 25a

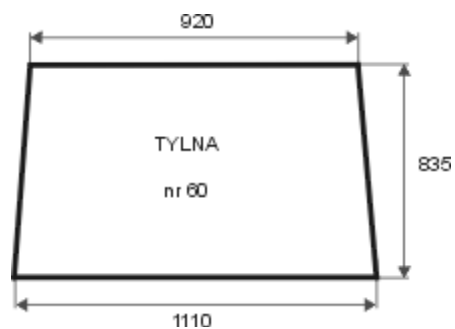
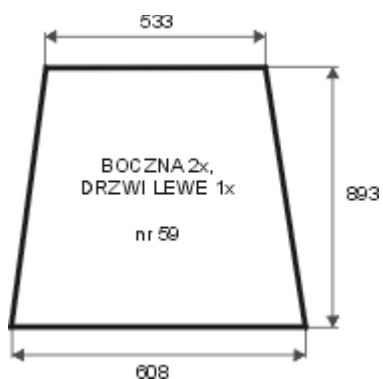
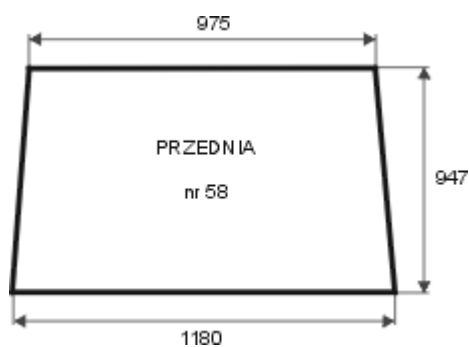
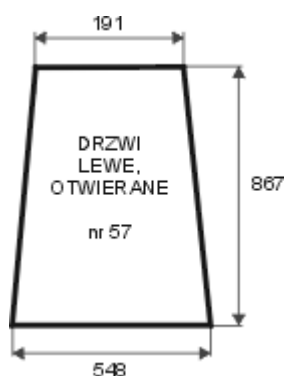

C – 330 Smolniki

(kabina firmy Koja)

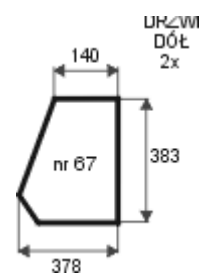
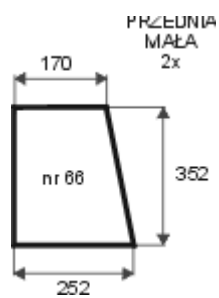
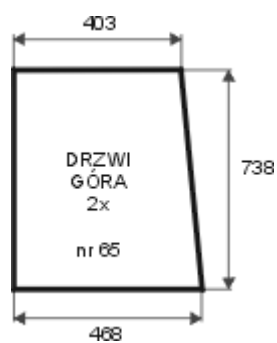
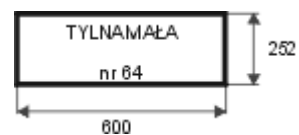
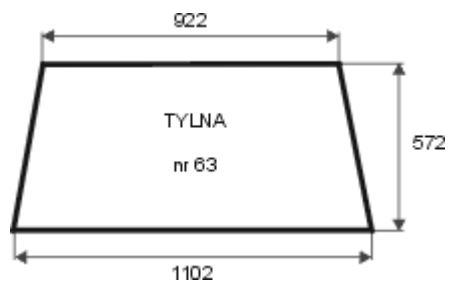
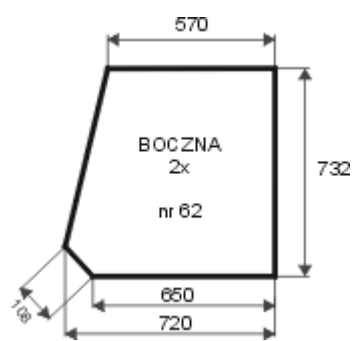
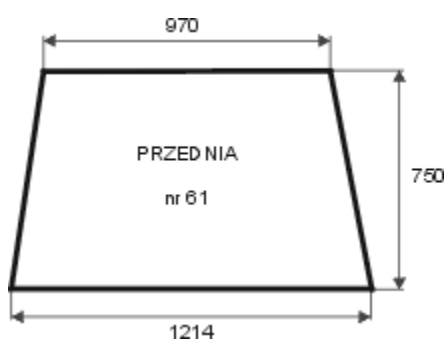

C – 330 Smolniki

(nowy typ) (kabina firmy Koja)

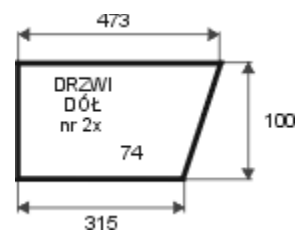
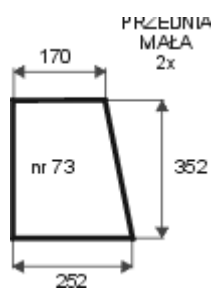
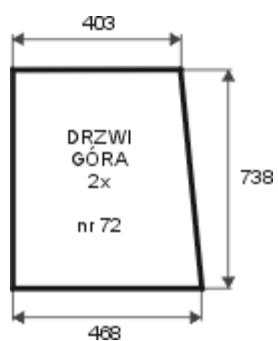
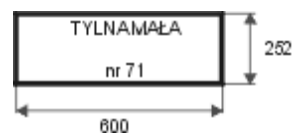
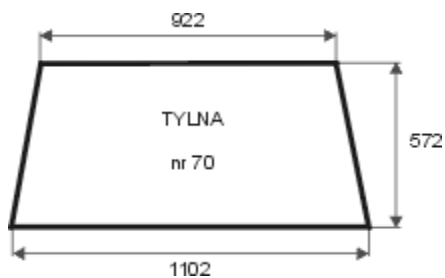
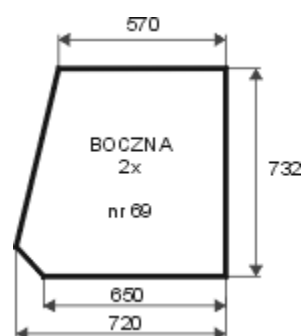
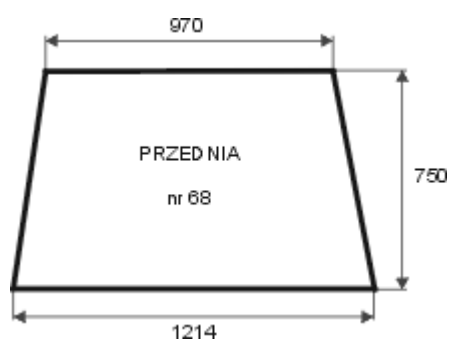

C – 330 Sokółka

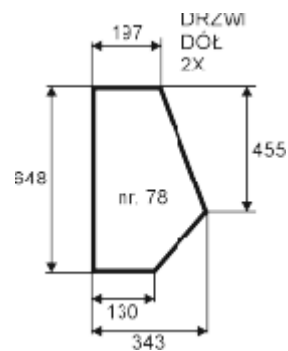
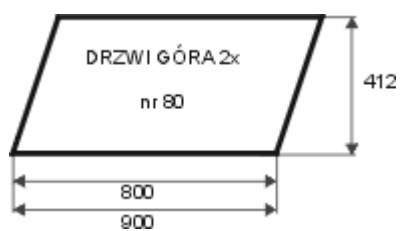
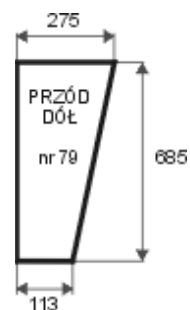
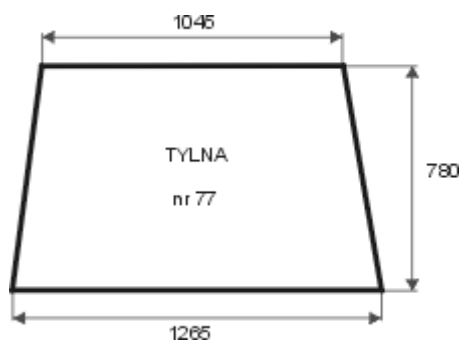
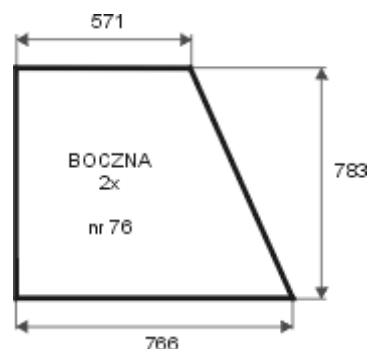
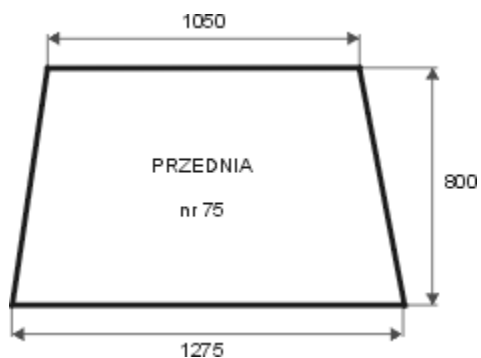

C – 360

(kabina w ramkach z rury kwadratowe)

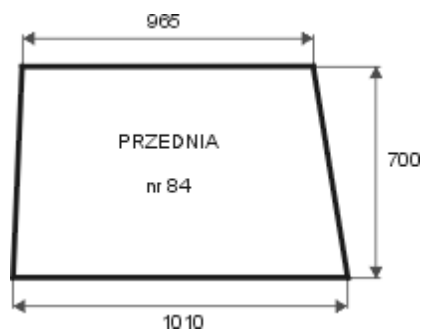
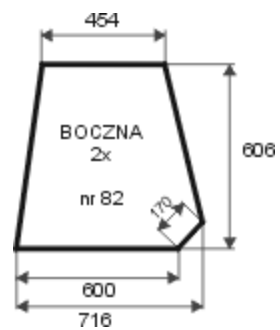
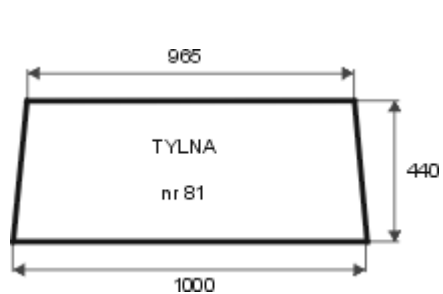

PRZÓD
DÓŁ, PRAWY



C – 360 kabina czeska



PRZÓD
DÓŁ, PRAWY

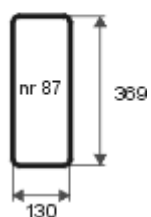

PRZÓD
DÓŁ, LEWY

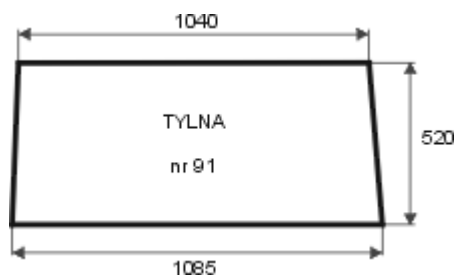
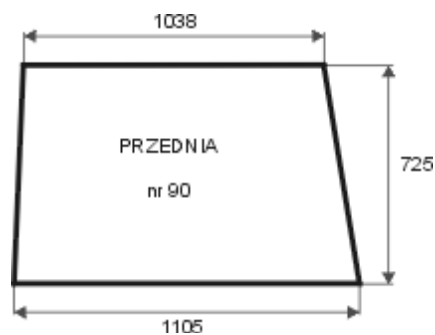
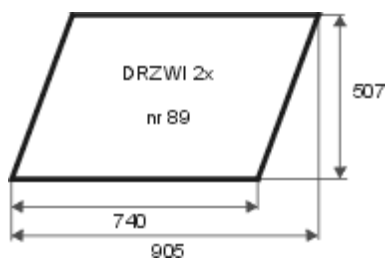
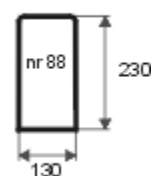

C – 360 kabina czeska (nowy typ)

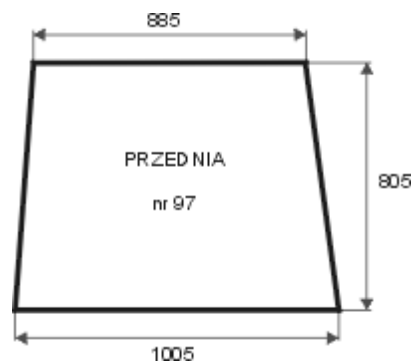
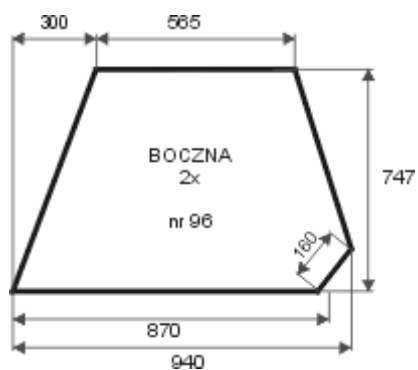
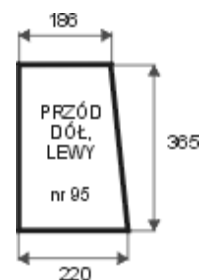
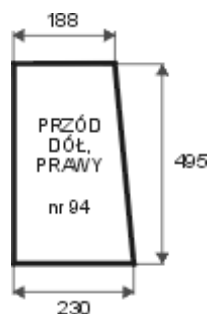
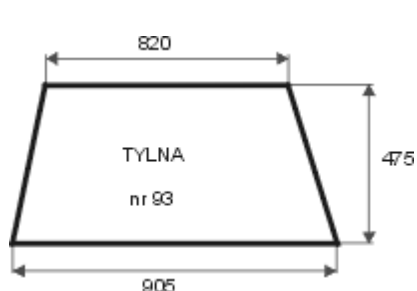
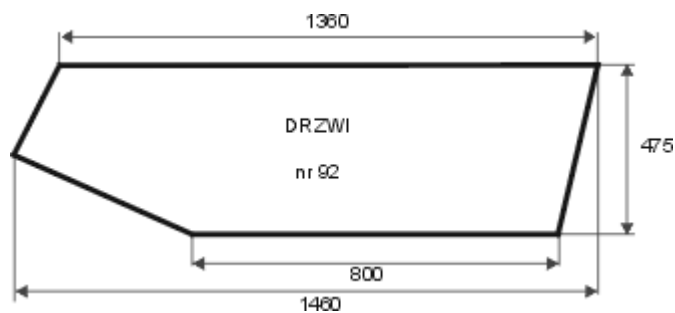

C – 360 Ciechocin

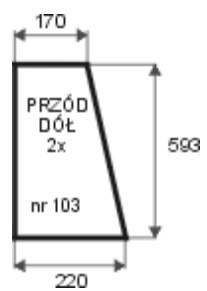
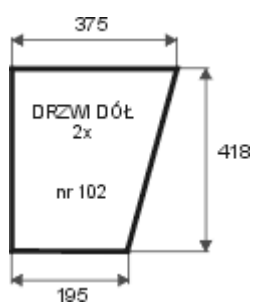
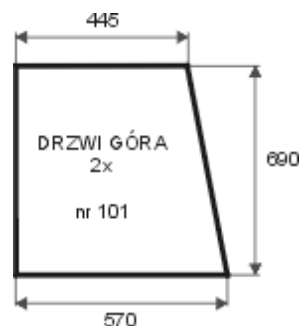
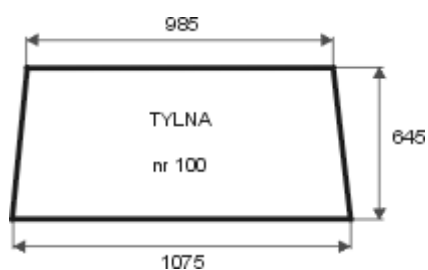
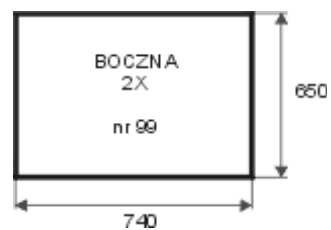
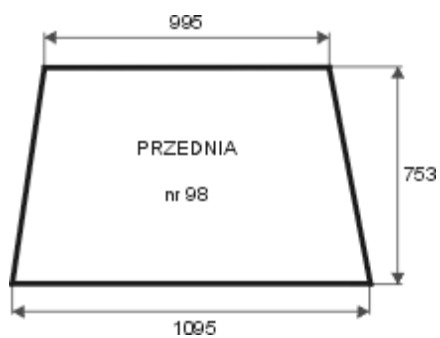

C – 360 *Kunów*

(blaszanka)

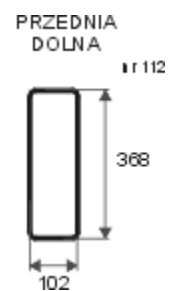
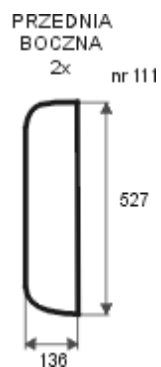
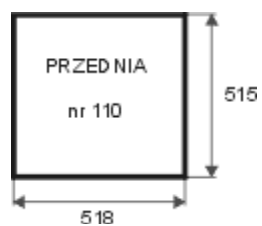
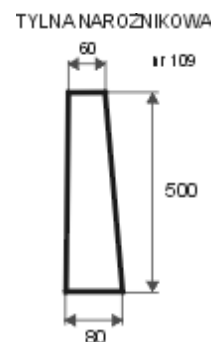
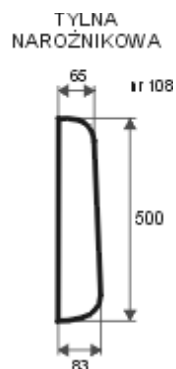
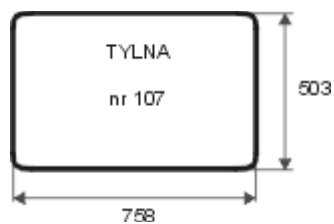
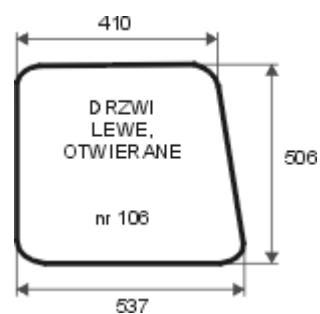
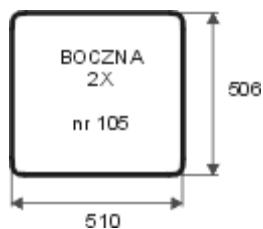
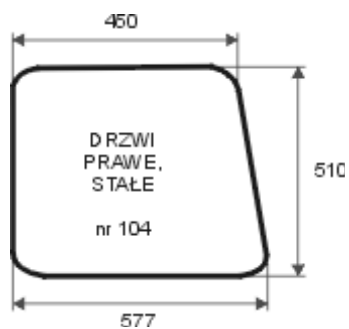

C – 360 *Kunów*

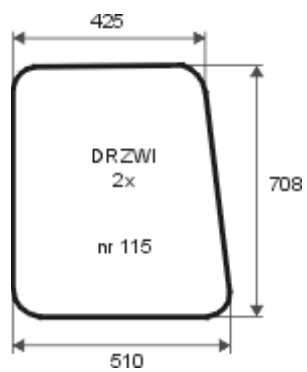
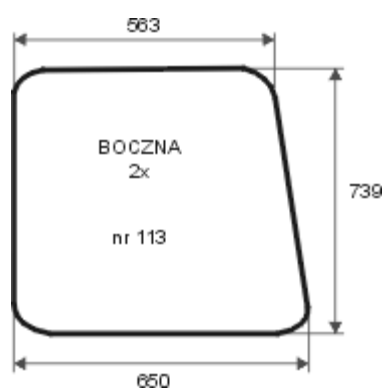

PRZEDNIA MAŁA, DOLNA 2x
TYLNA MAŁA, DOLNA 1x

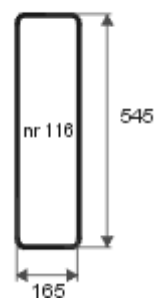

C – 360 *Kunów*

(nowy typ)

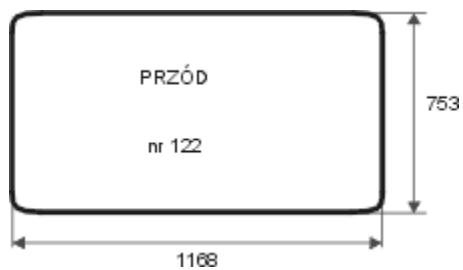
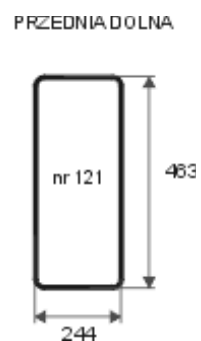
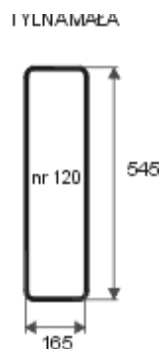
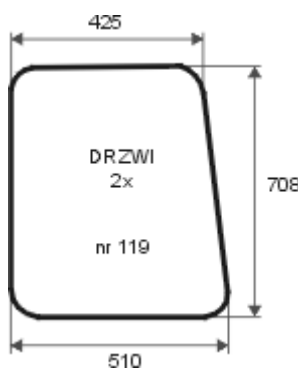
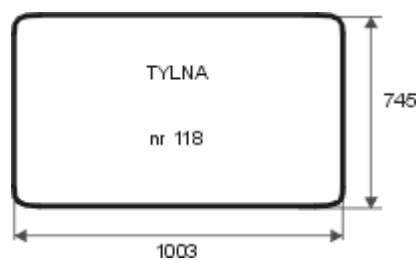
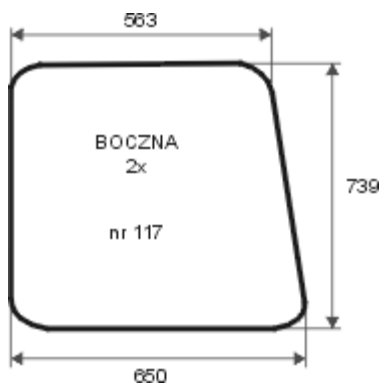

C – 360 Lubsko

(rok produkcji 1985)

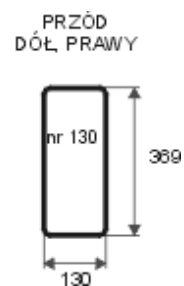
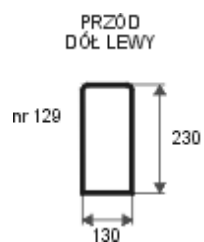
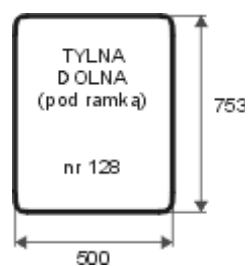
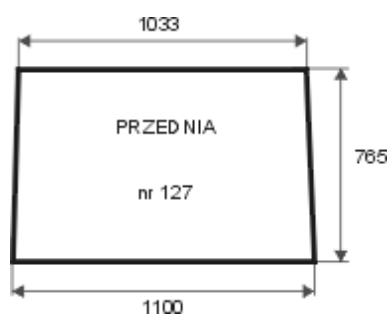
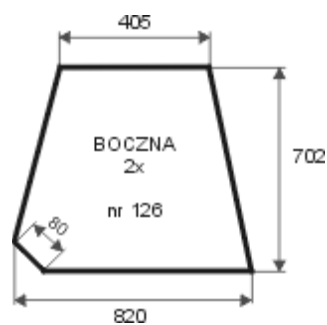
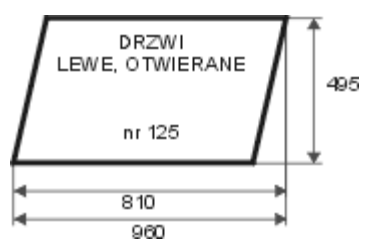
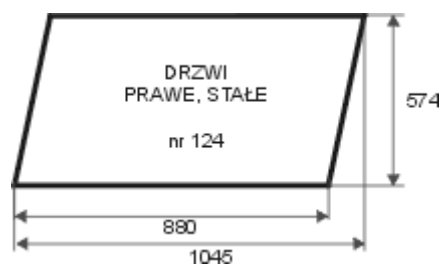
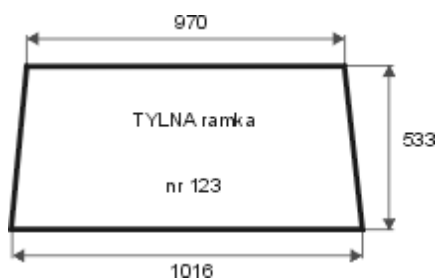

C – 360 Lubsko

(rok produkcji 1985)

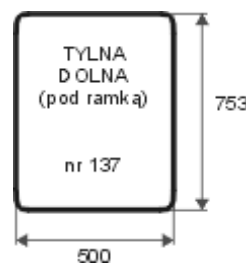
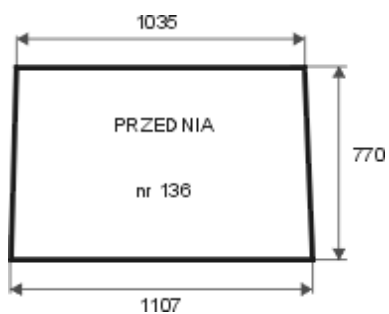
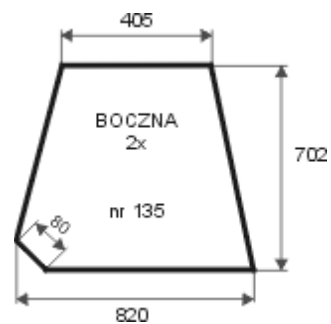
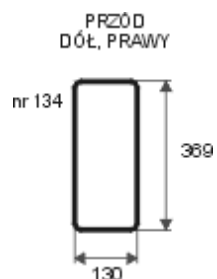
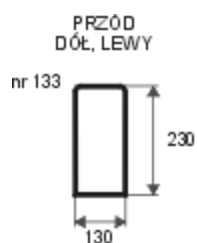
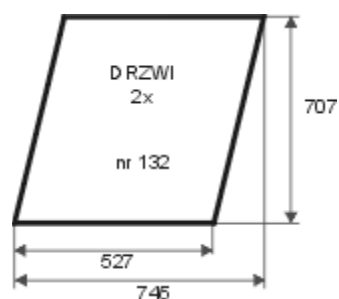
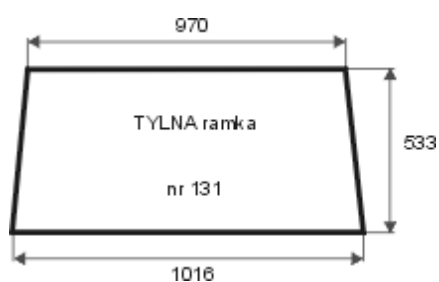

C-360 POM Zamość

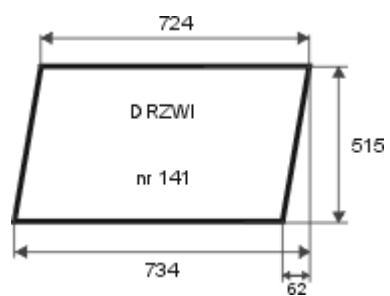
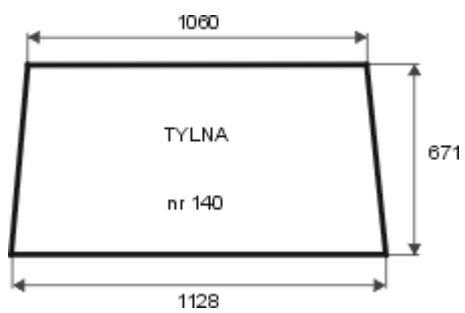
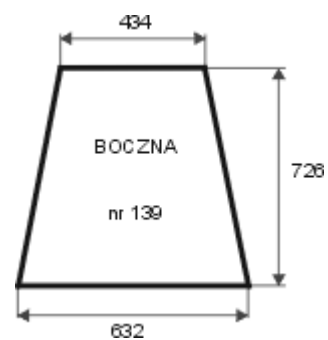
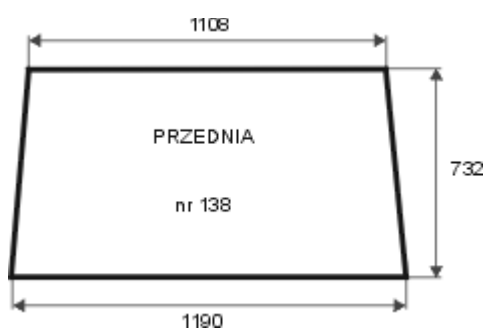

C – 360 Smolniki

(kabina firmy Koja)

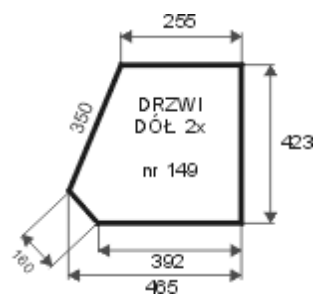
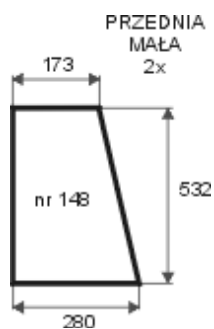
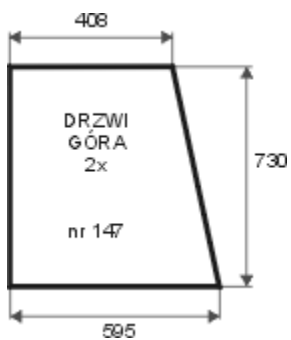
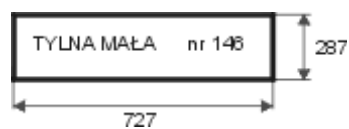
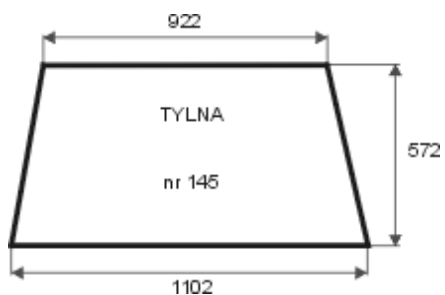
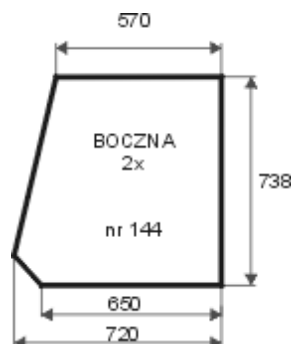
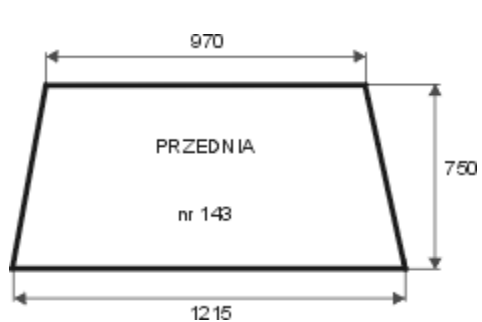

C – 360 **Smolniki**
(nowy typ) (kabina firmy Koja)

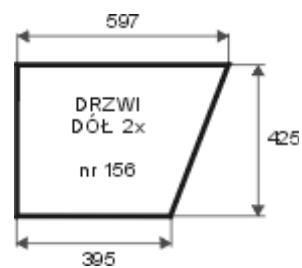
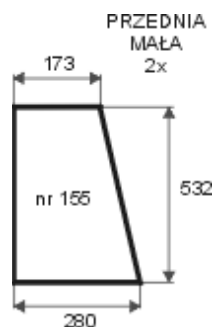
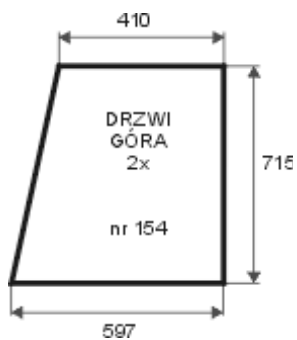
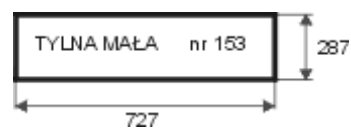
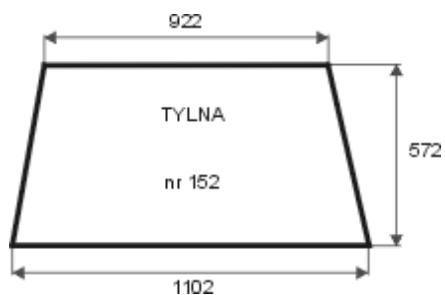
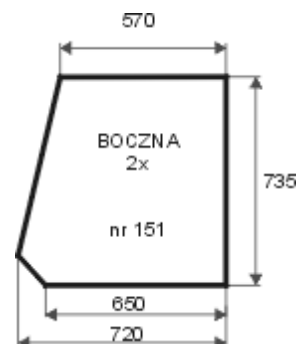
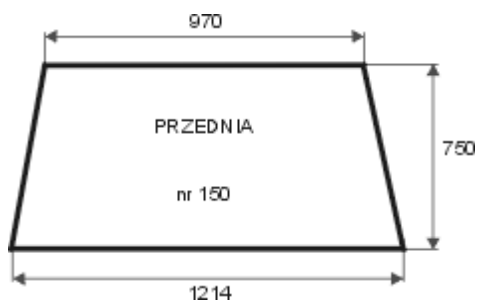

C – 360 Sokółka

(typ KCR – 360)

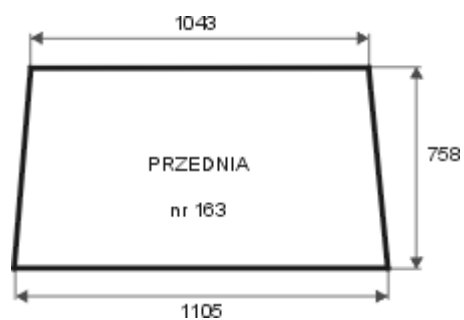
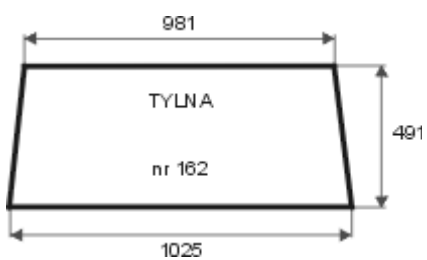
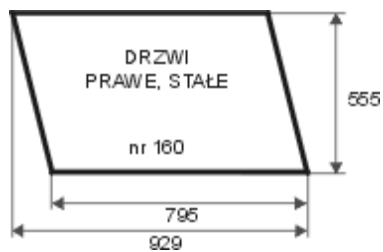
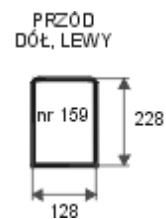
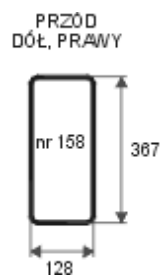
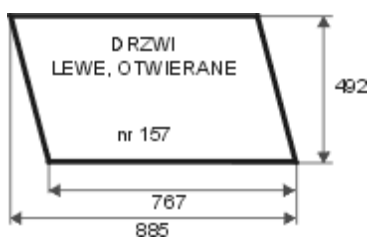

C – 360 Sokółka



(nowy typ)

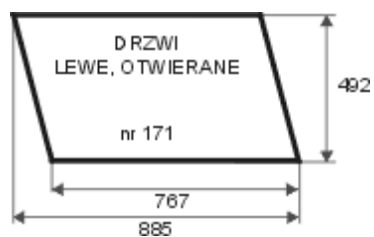
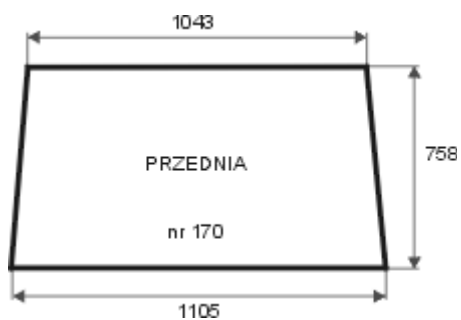
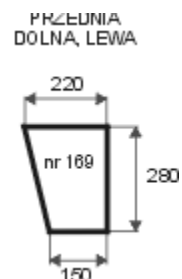
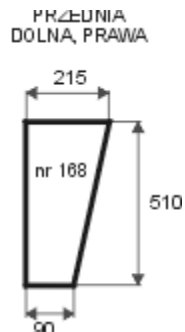
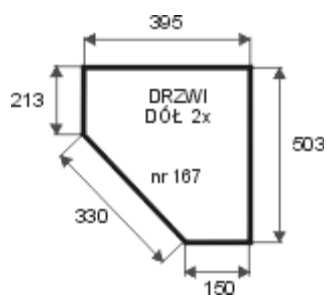
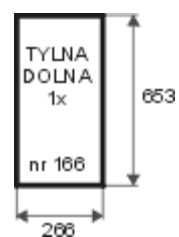
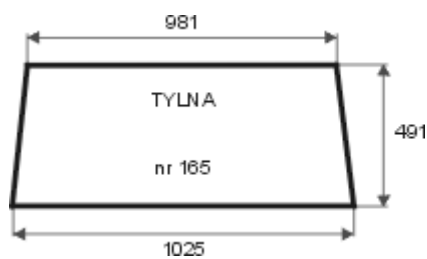
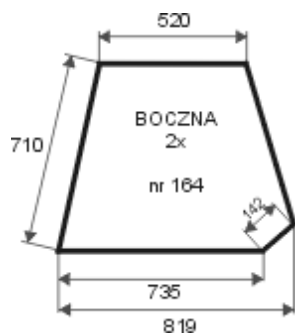

C – 360 Szczytno

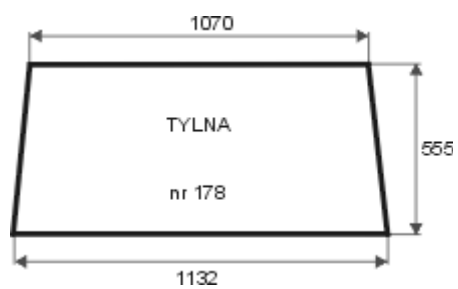
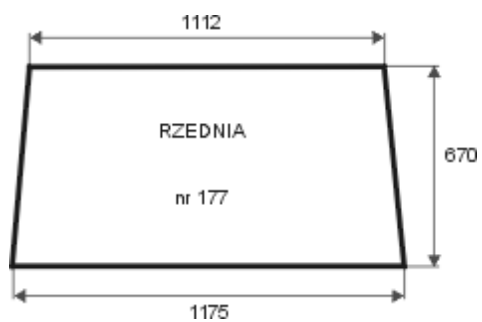
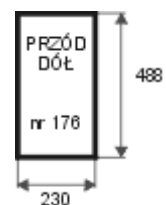
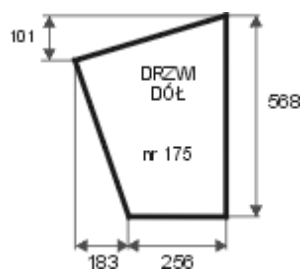
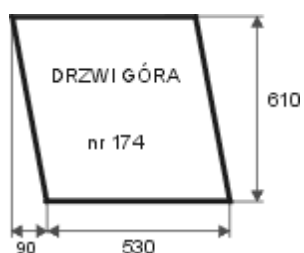
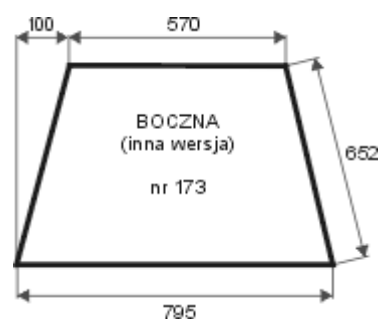
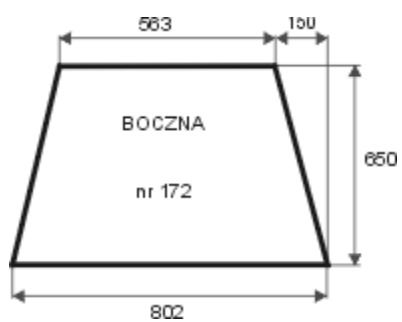

C – 360 Szyszka Koźmin

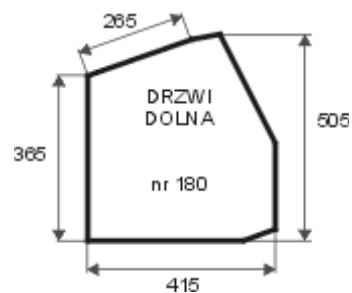
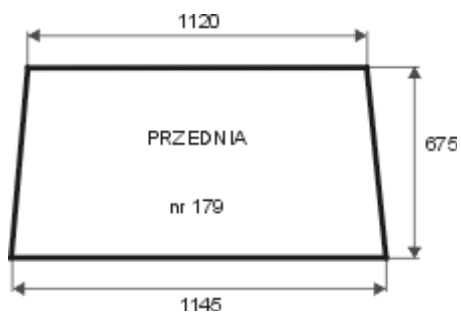

TYLNA MAŁA

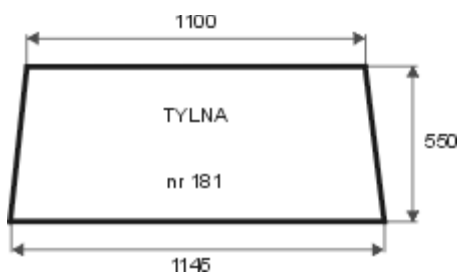
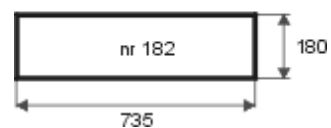

PRZEDNIA MAŁA

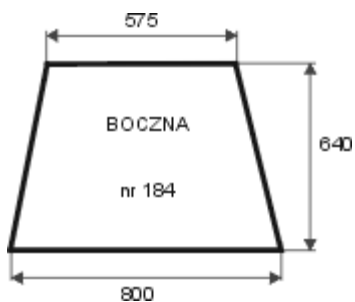
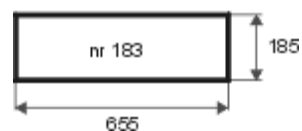

C – 360



Spół. Rzemieślnicza Mechaników WROCLAW

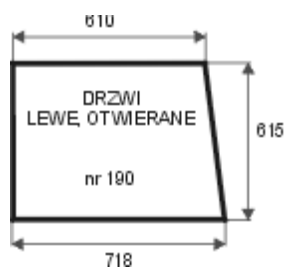
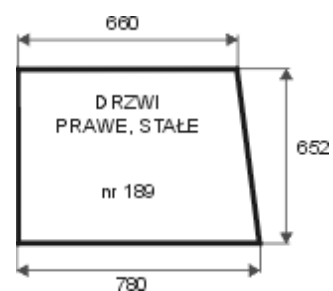
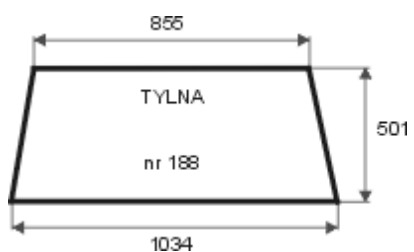
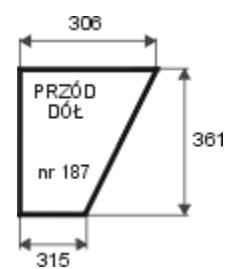
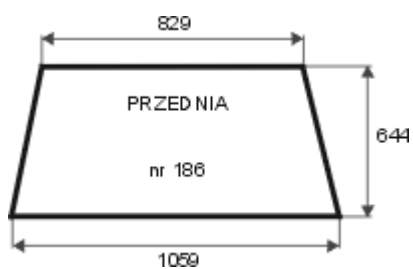

Zetor 5011, 5211

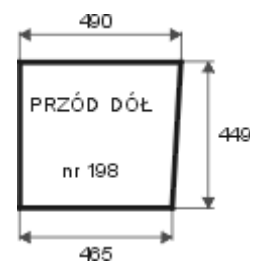
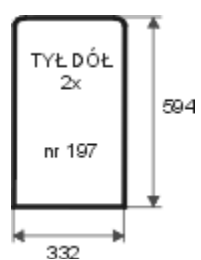
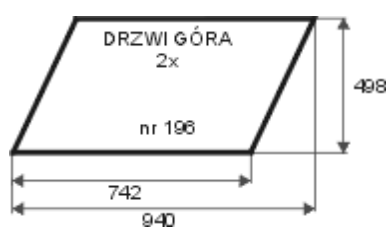
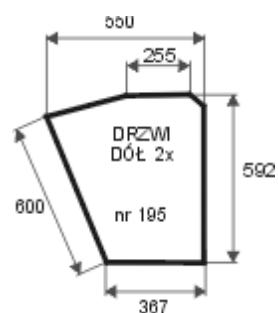
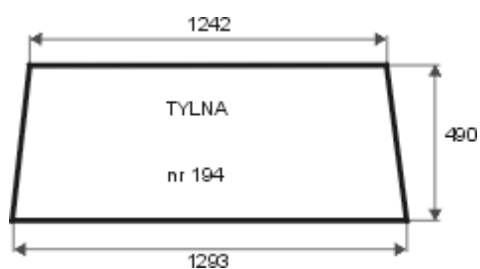
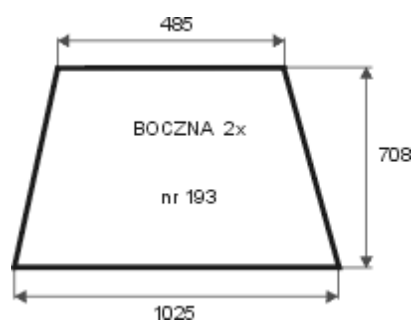
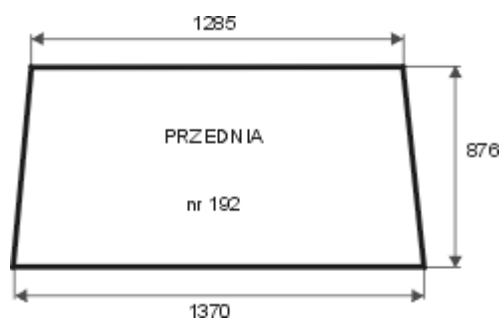

Zetor 5611, 5718

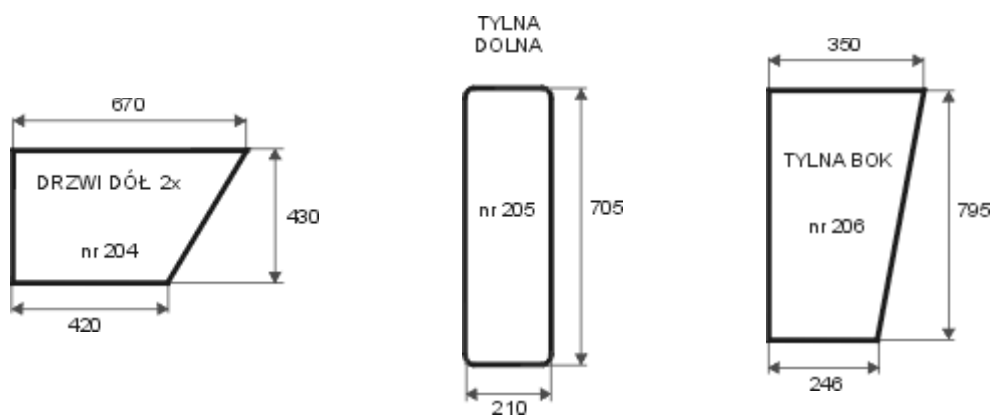
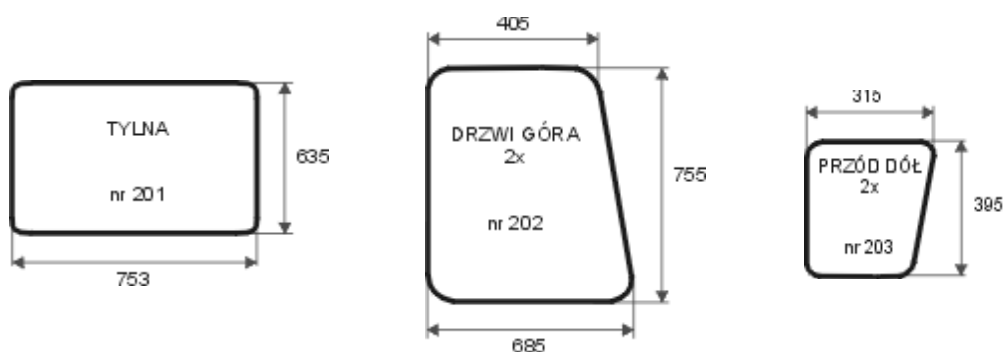
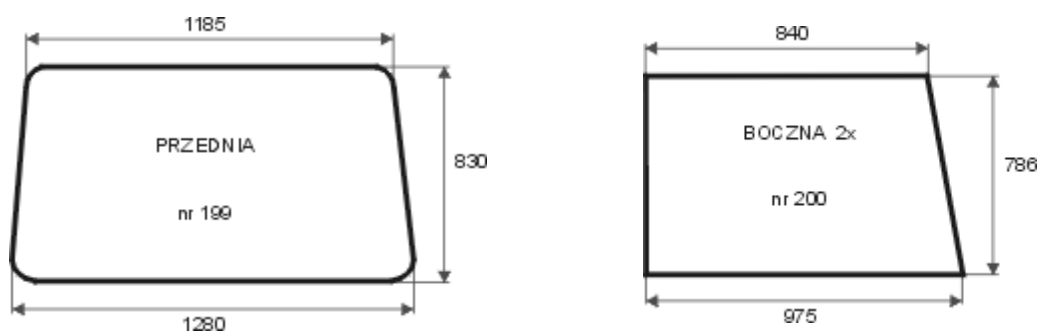

Zetor 7011

typ BK 5911

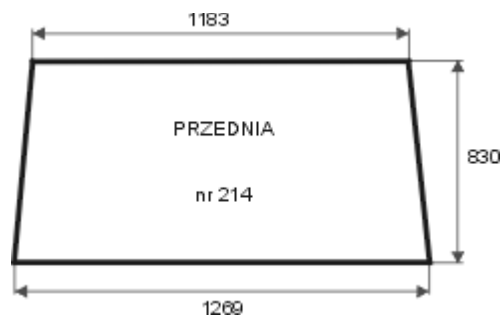
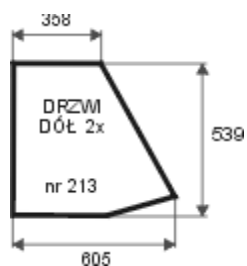
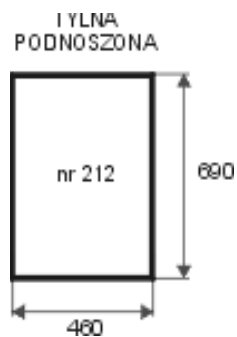
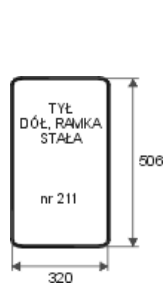
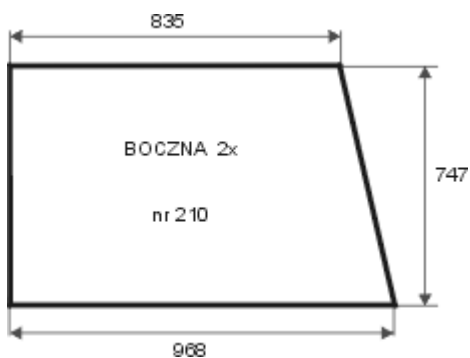
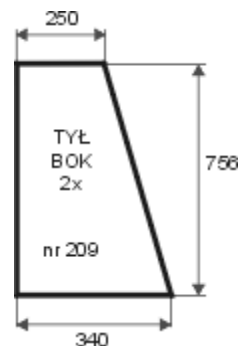
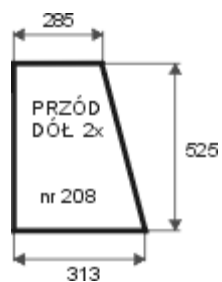
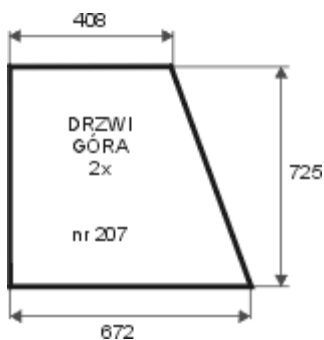

Zetor 7211, 7245, 5211, 6340, 5320, 7340



Typ BK 6011s

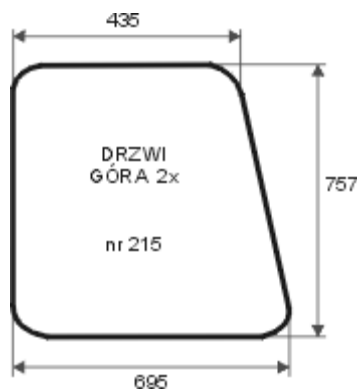

3 otwory

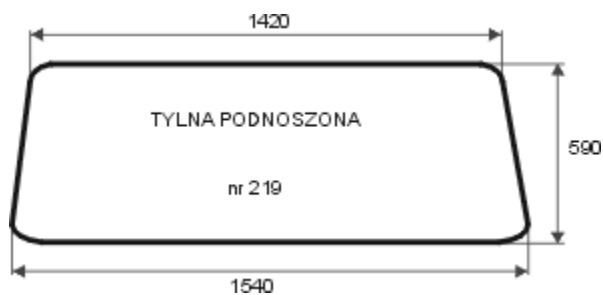
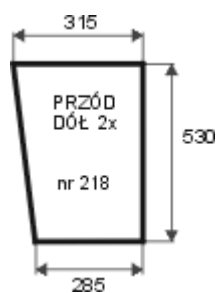
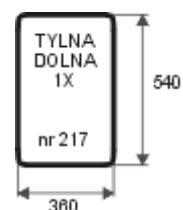
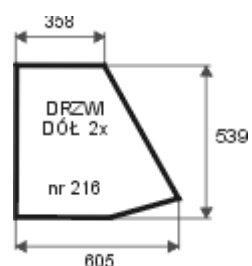

5 otworów

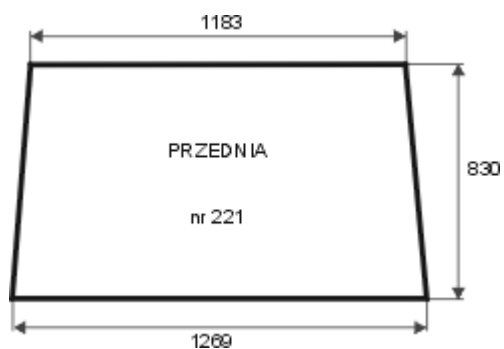
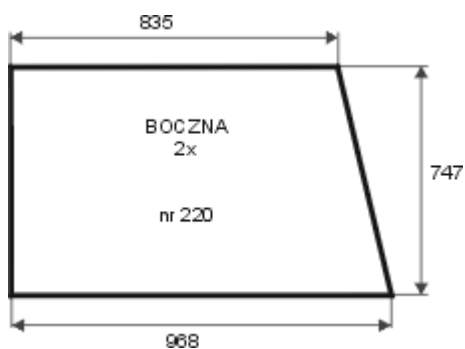

Zetor 7211

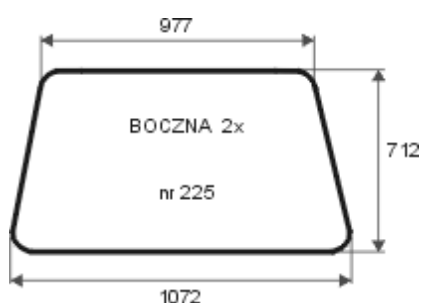
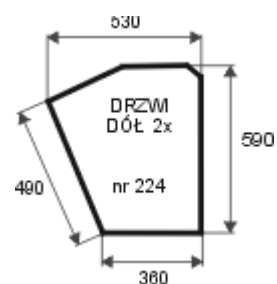
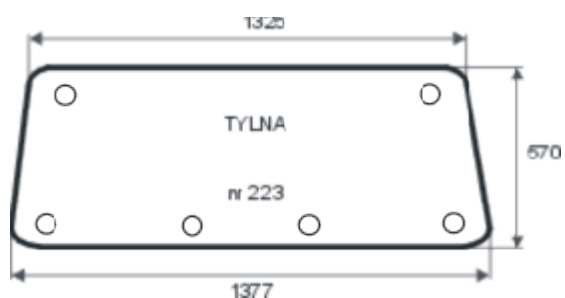
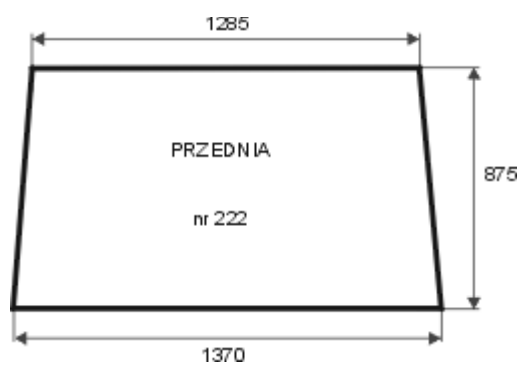

4 otwory

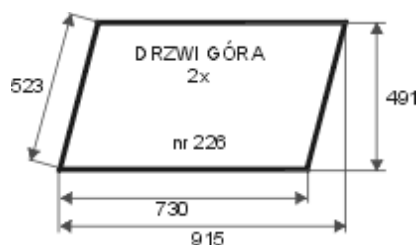

W ofercie dostępna także grzewcza szyba nr 223

Zetor 10540, 9540

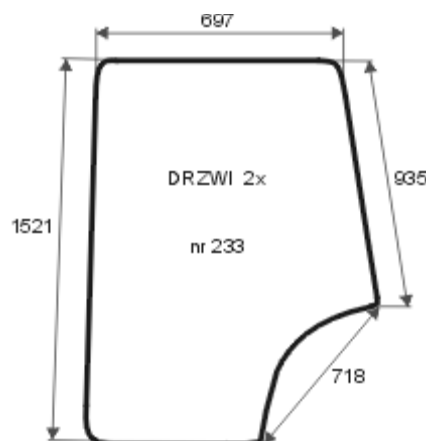
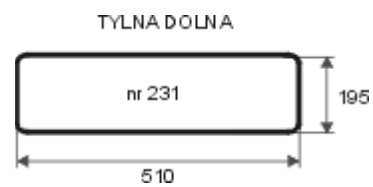
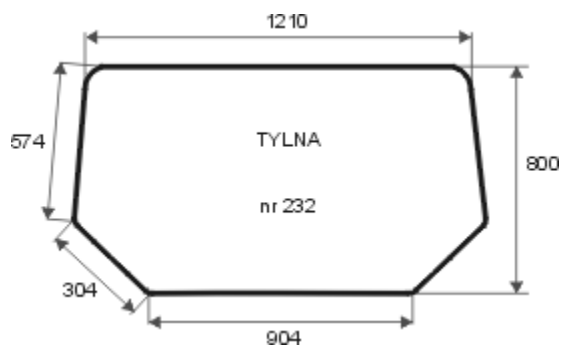
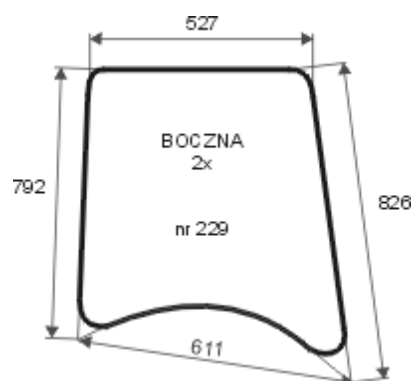
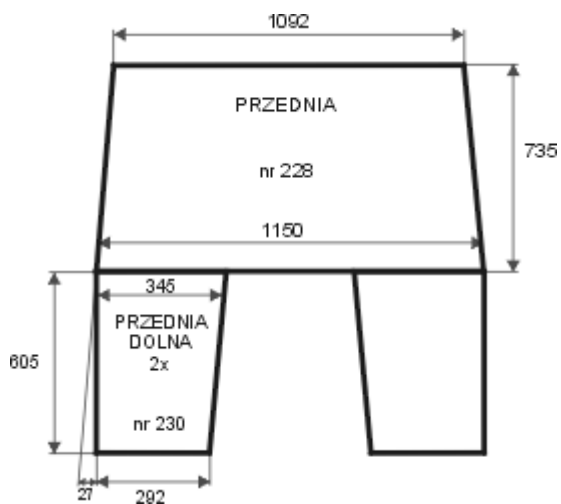

Zetor 12111, 16145

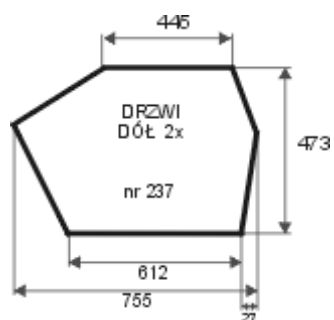
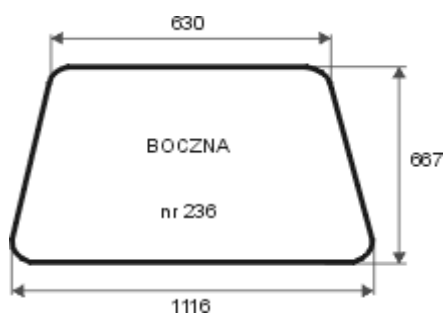
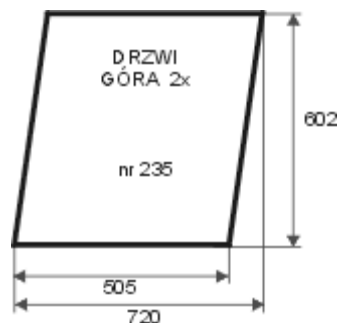
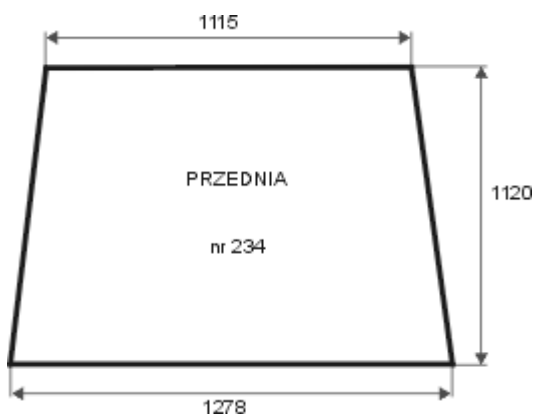

4 otwory

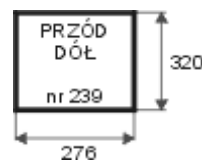
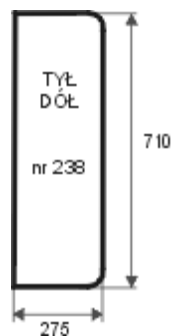
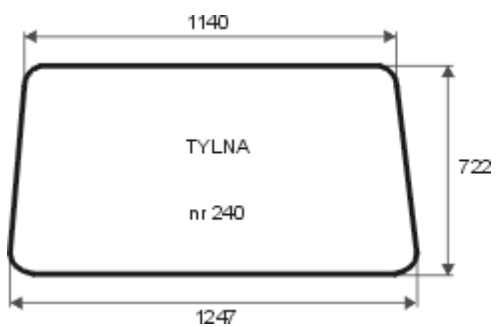

7 otworów

W ofercie dostępna także grzewcza szyba nr 240

Zetor 12245 16245

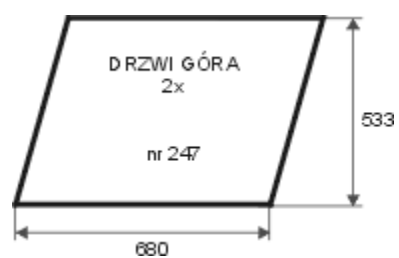
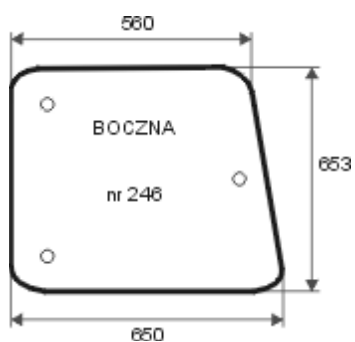
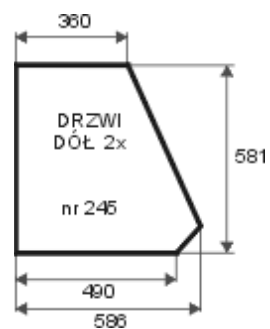
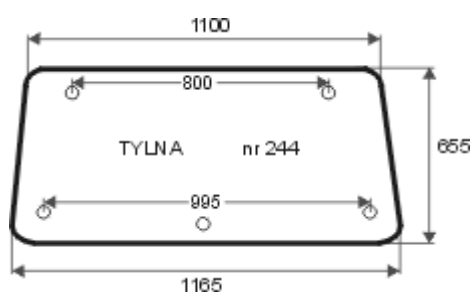
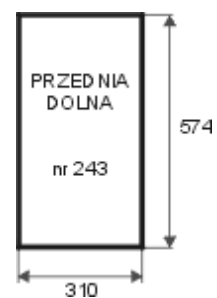
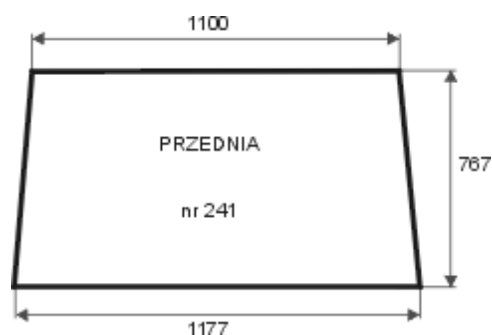

Kabina do ciągnika Zetor

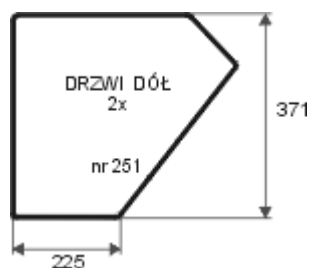
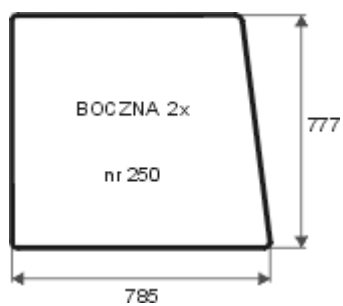
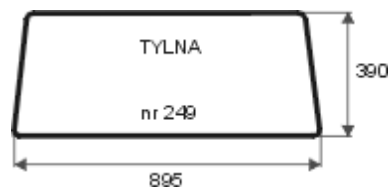
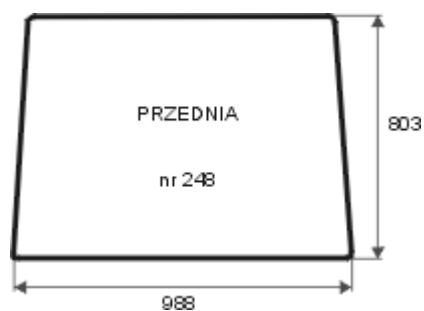

Ursus Nimet DE 25T

Smolniki Koja

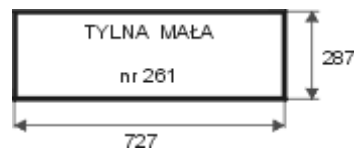
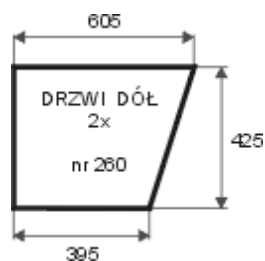
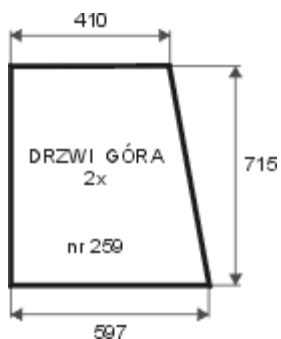
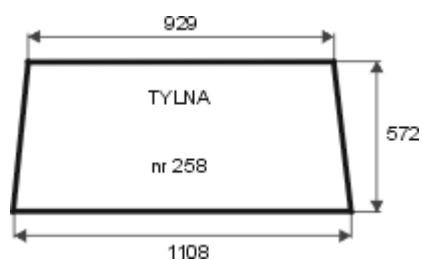
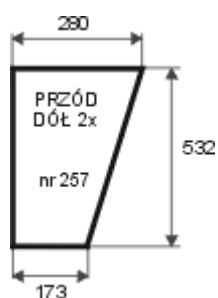
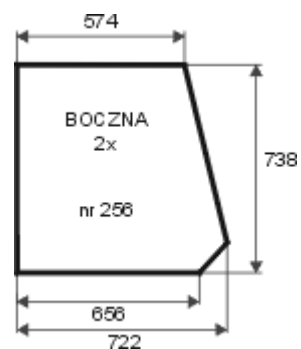
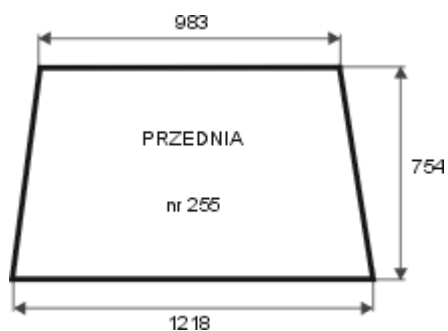

Ursus 912

Typ 80354 Kunów 385 – nowy typ

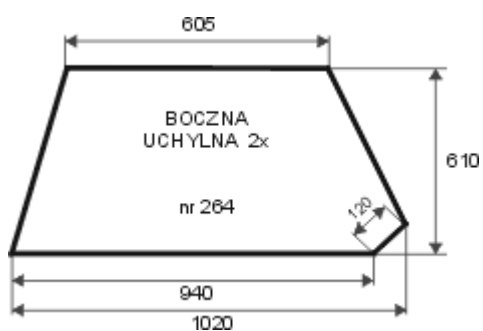
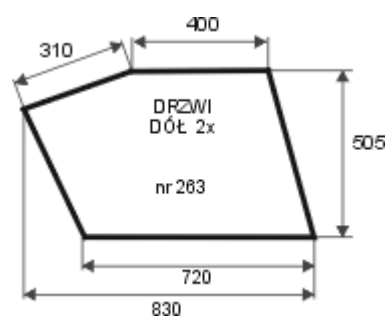
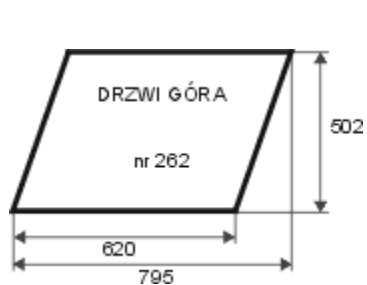

4 otwory

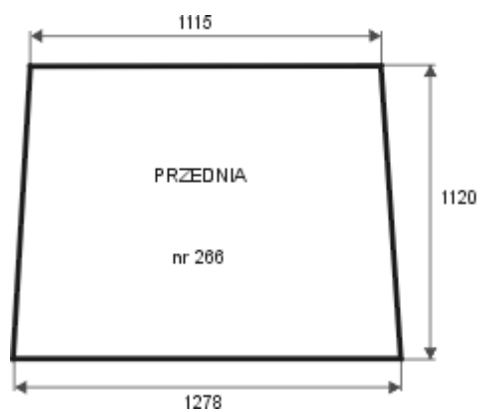
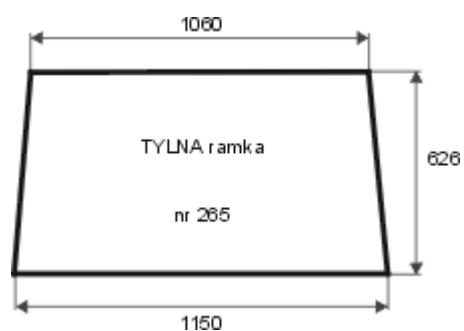

Ursus 1604 (1201)

Typ 1204 Kunów 385 - stary typ

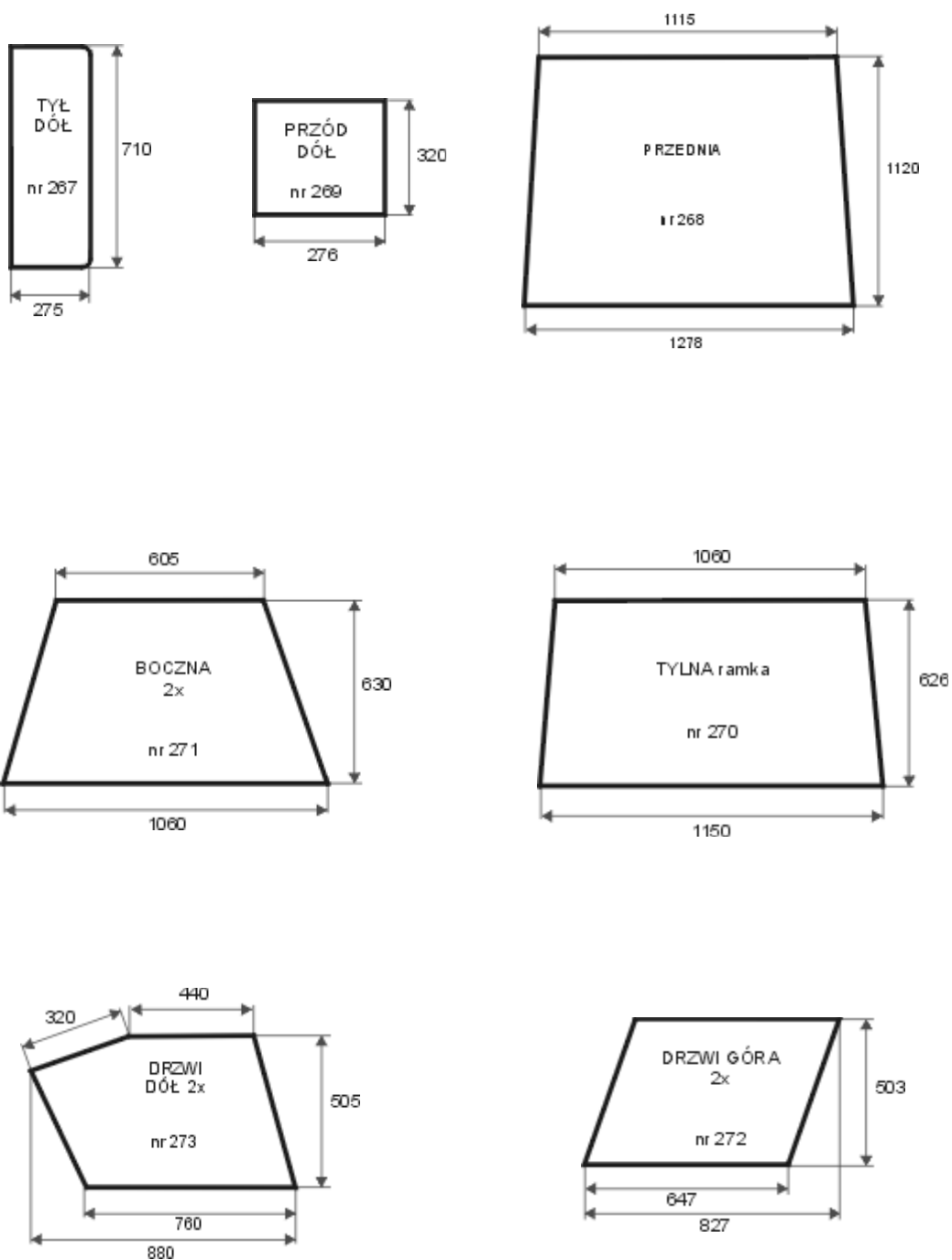

Ursus 1634

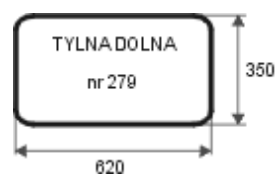
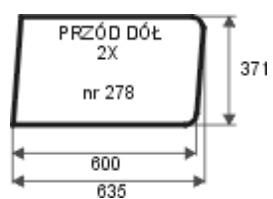
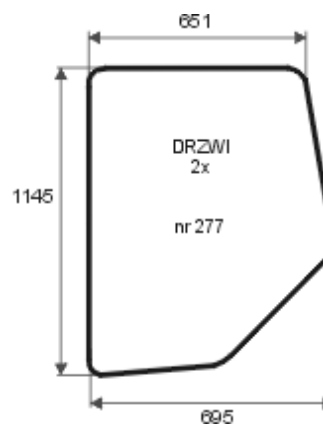
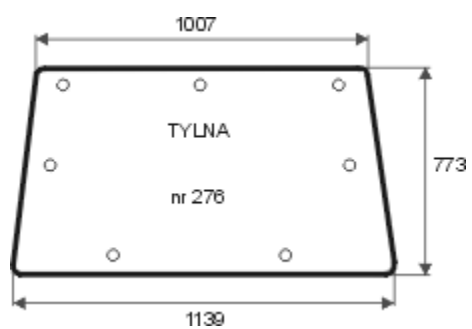
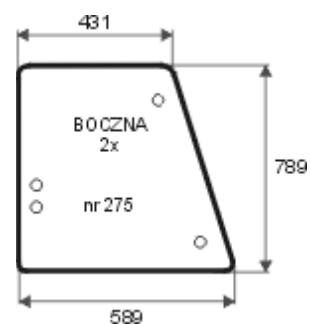
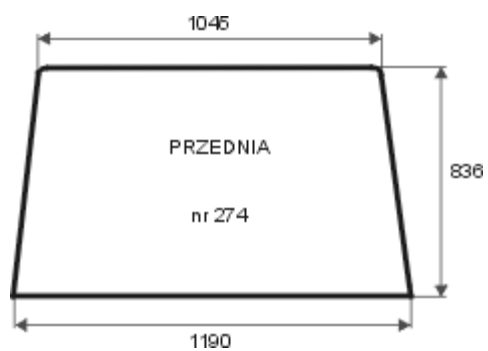

Ursus 2802

Ogrodnik Smolniki Koja

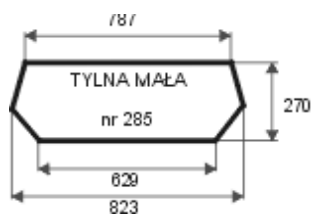
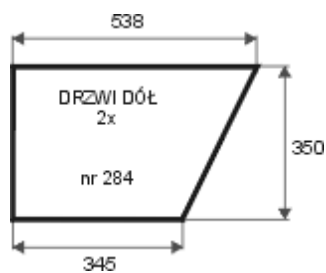
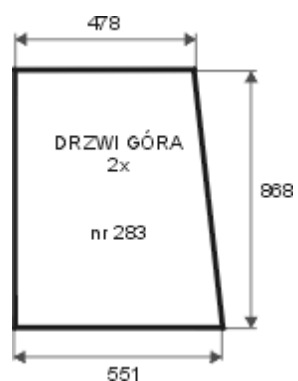
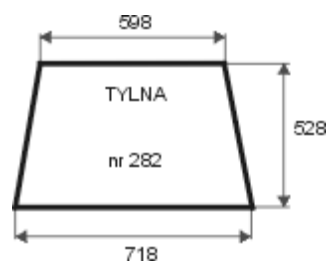
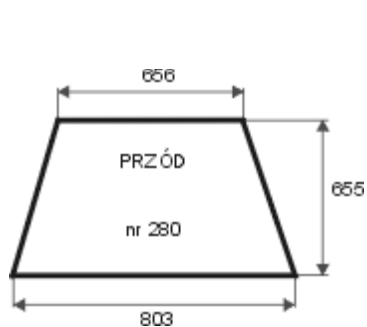

Ursus 28 – 12

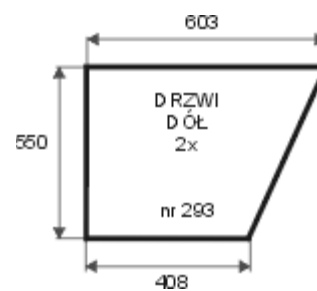
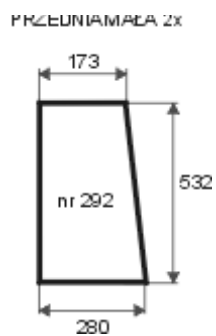
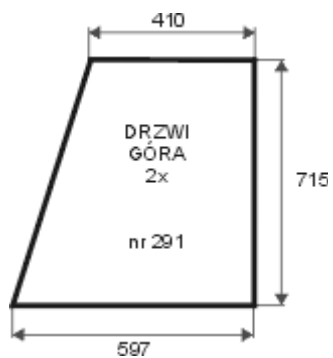
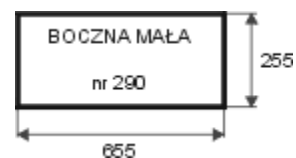
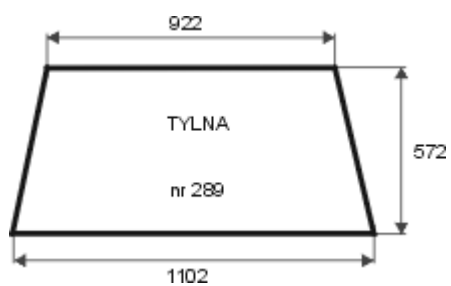
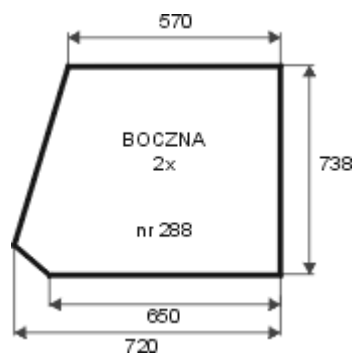
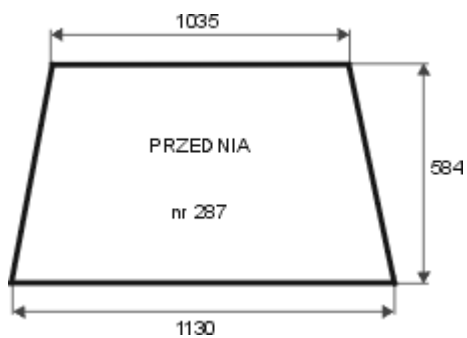

Ursus 3502

(stary typ) - Ogrodnik Smolniki Koja

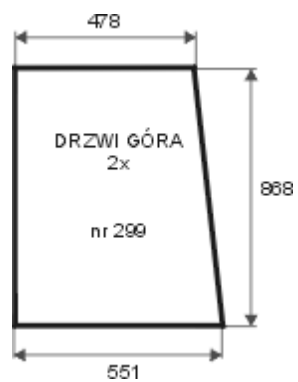
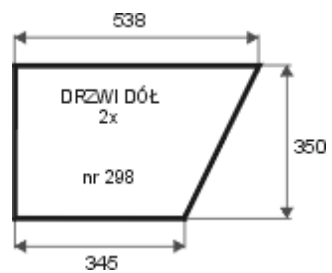
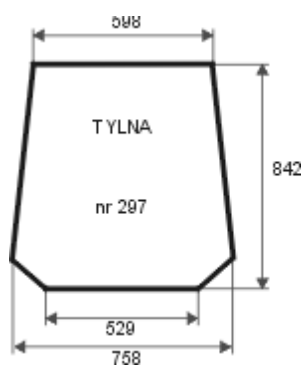
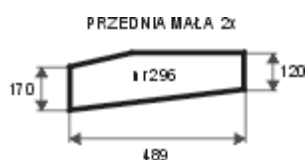
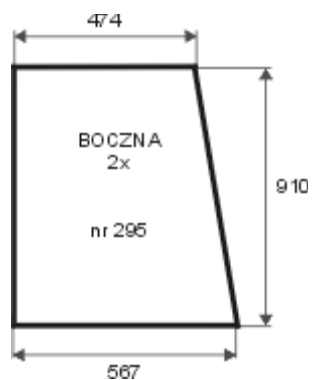
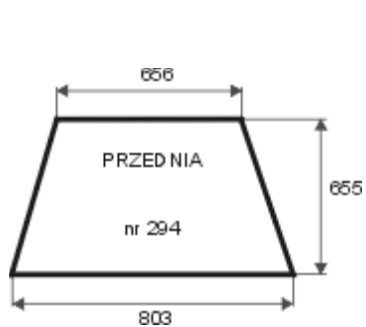

Ursus 3502

(nowy typ) - Ogrodnik Smolniki Koja

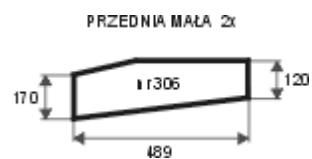
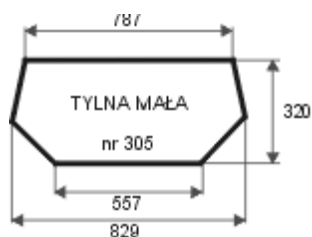
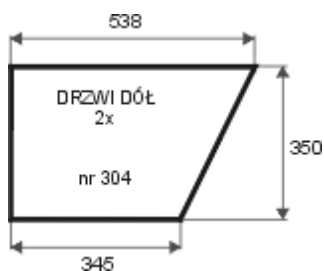
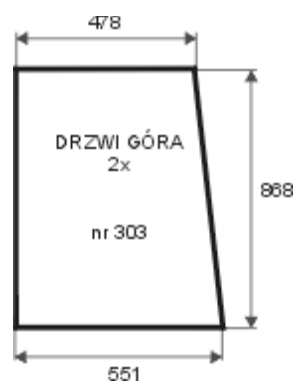
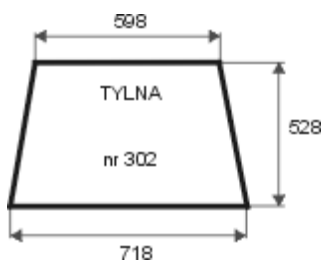
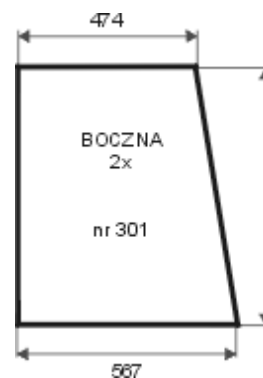
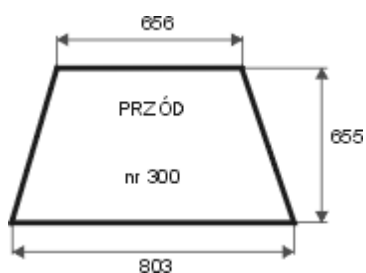

Ursus 35 – 12 Kunów

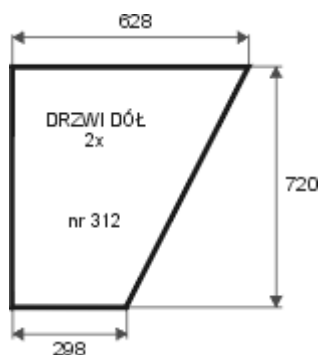
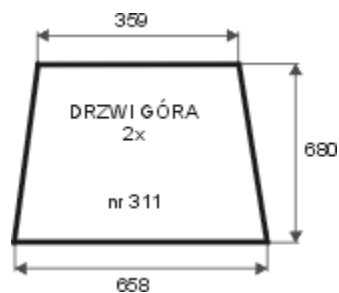
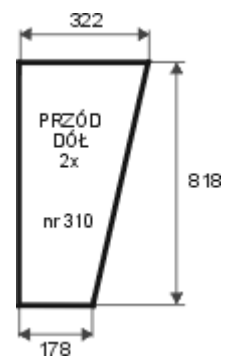
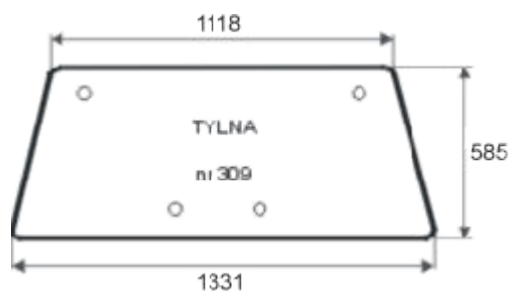
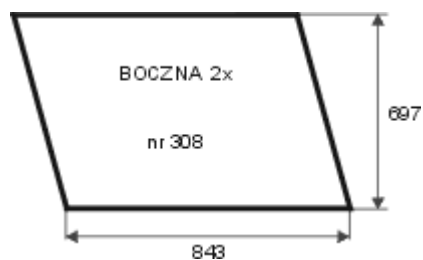
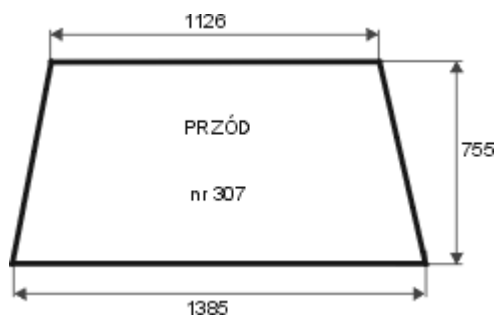

Ursus 35 – 12



(nowy typ)

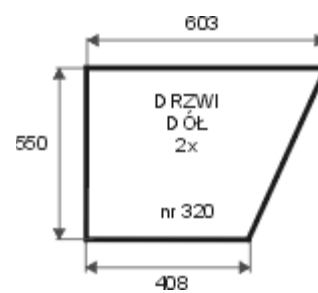
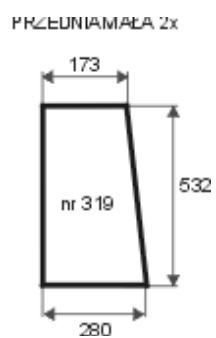
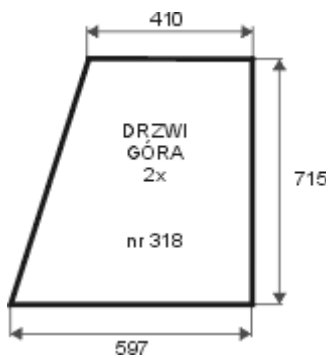
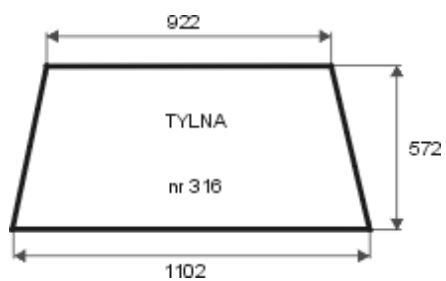
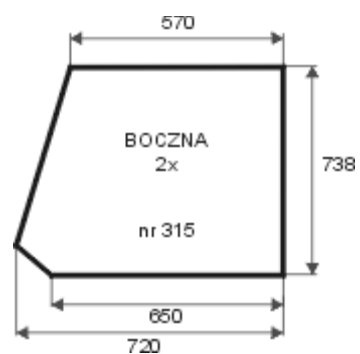
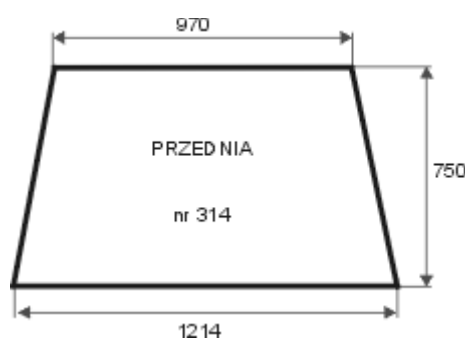

Ursus 4512, 4514, 5314

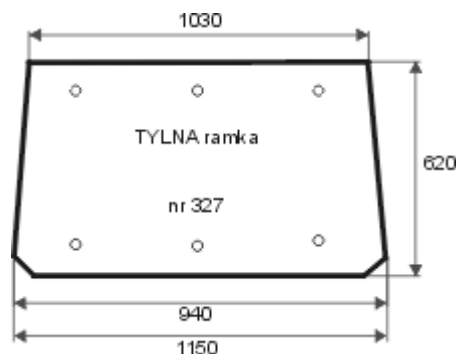
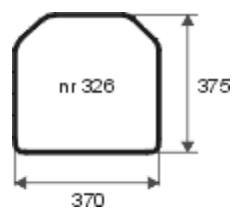
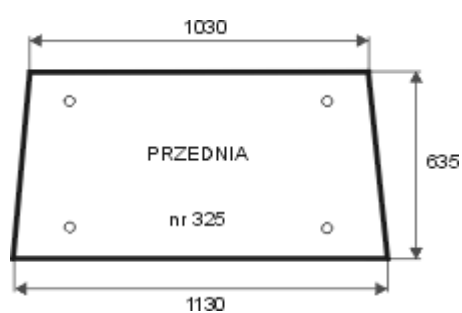
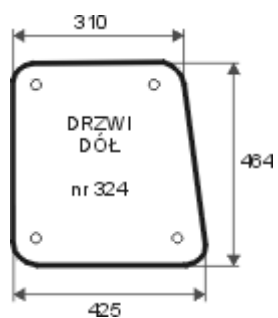
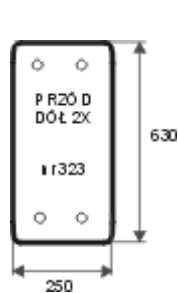
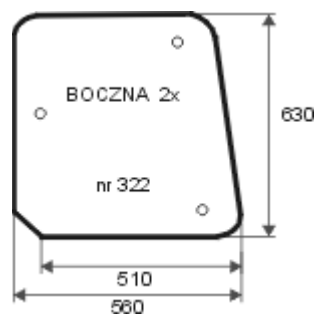
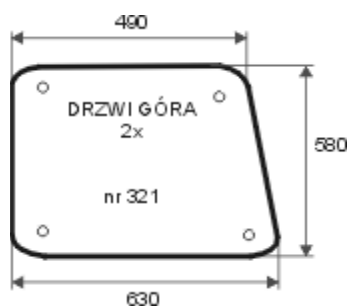

Tyłna dolna

MF Ciechocin

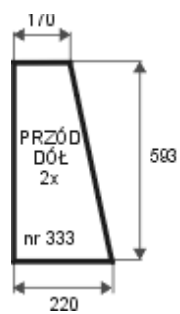
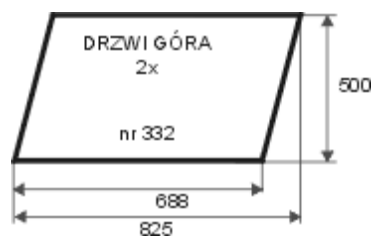
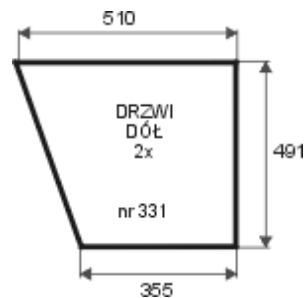
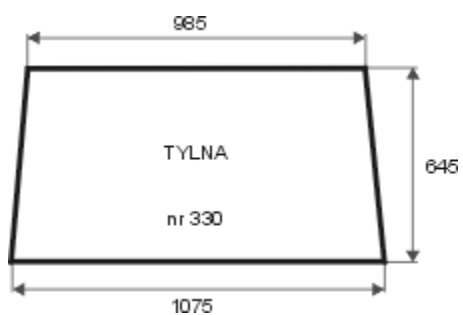
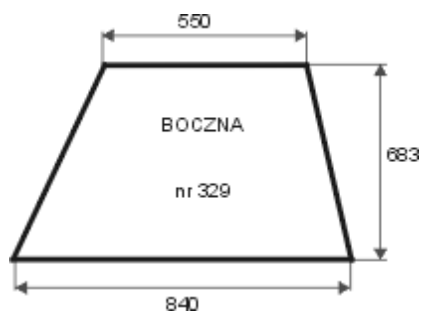
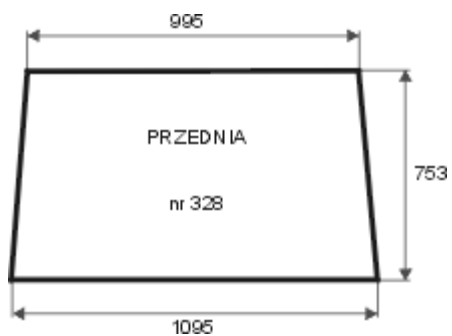

MF - 225 Smolniki



(kabina firmy Koja)

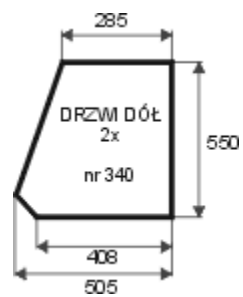
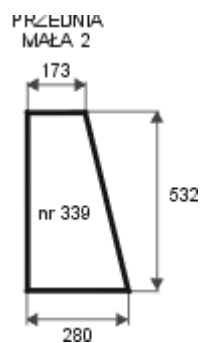
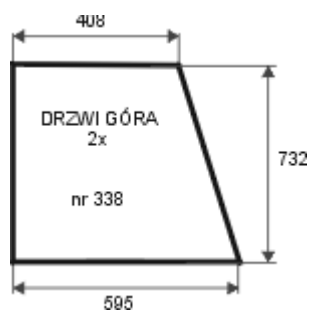
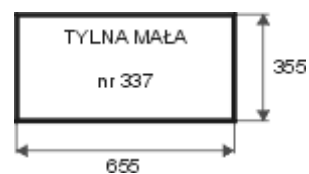
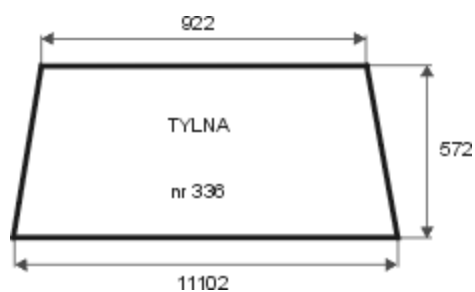
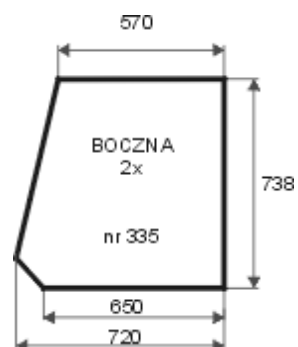
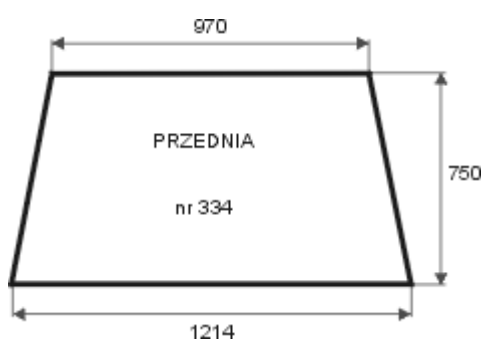

MF - 225 Smolniki



(Ursus 35-12) (kabina firmy Koja) (nowy typ)

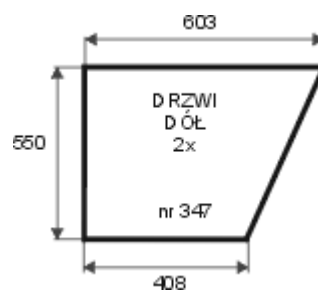
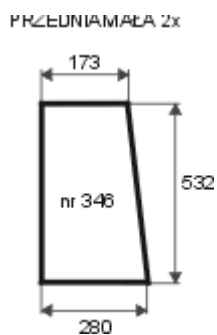
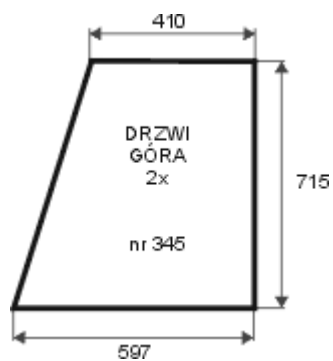
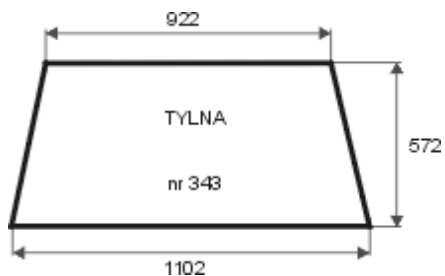
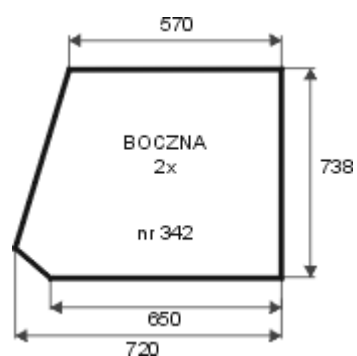
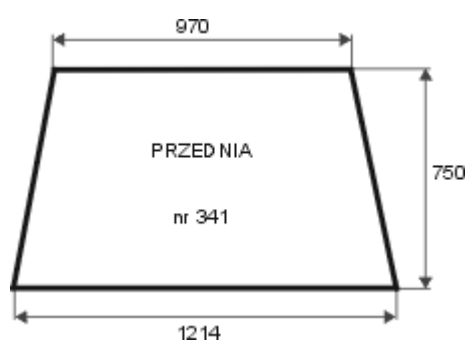

MF - 235 Luboń k. Poznania

(stary typ)

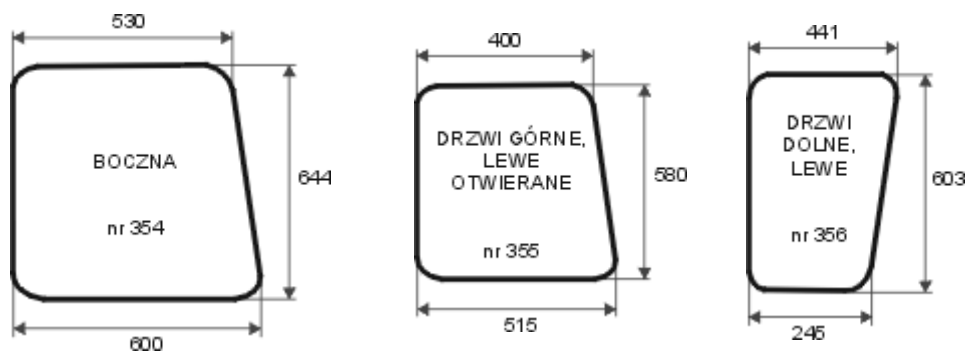
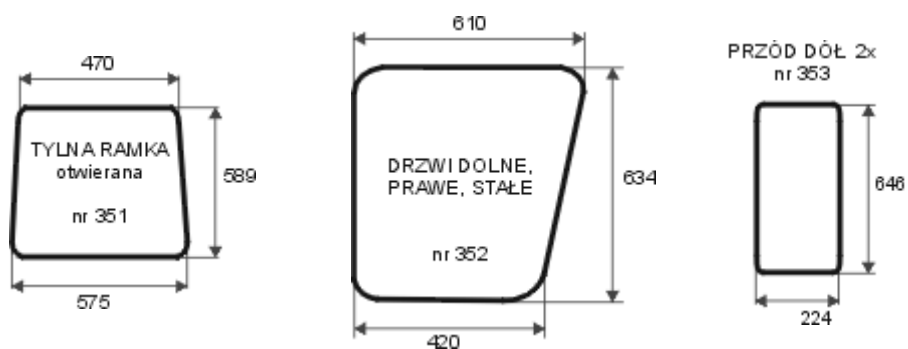
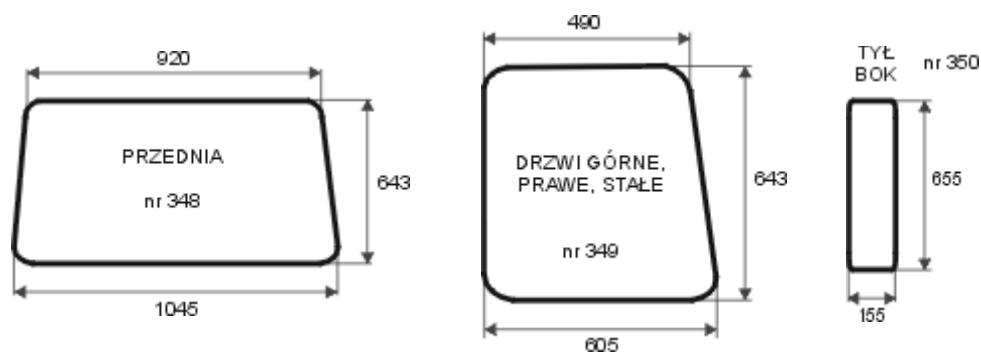

MF - 235 POM Zamość

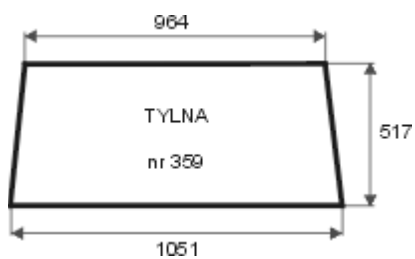
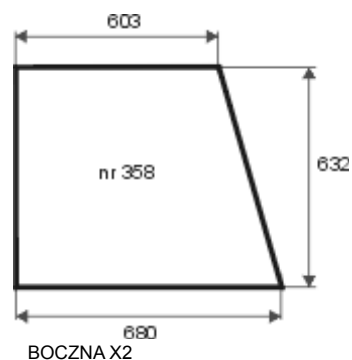
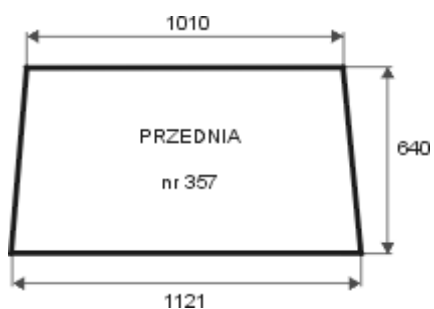

PRZEDNIA DOLNA

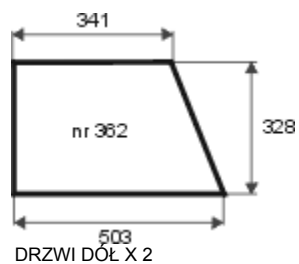

MF - 235 Smolniki

(kabina firmy Koja)

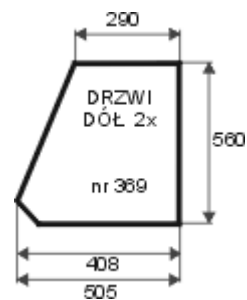
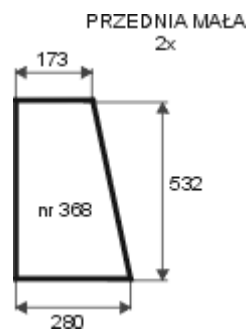
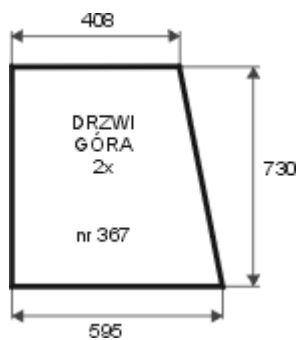
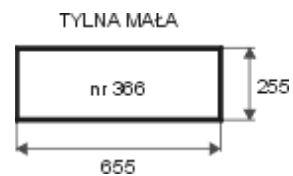
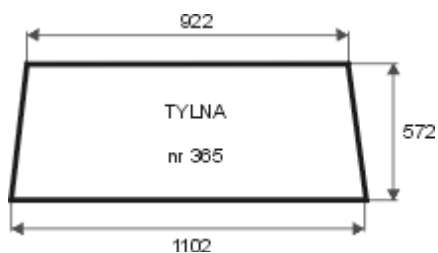
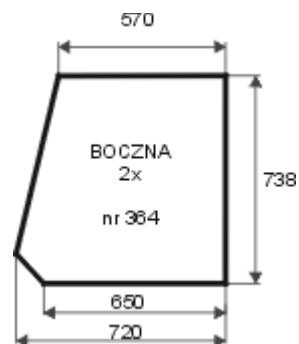
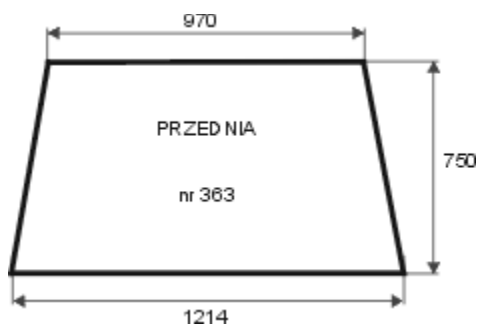

MF - 235 Smolniki
(Ursus 28-12) (kabina firmy Koja)

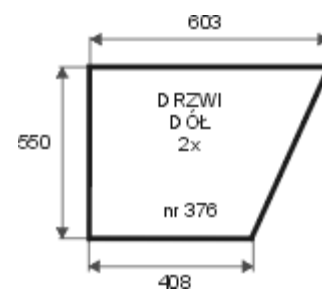
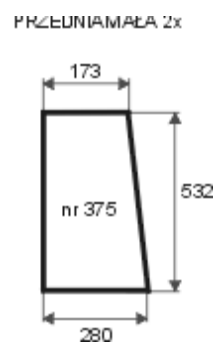
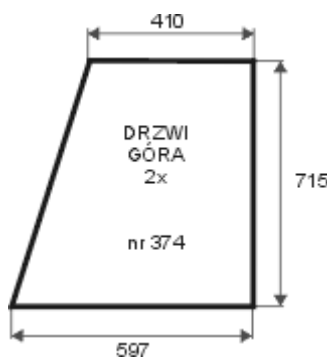
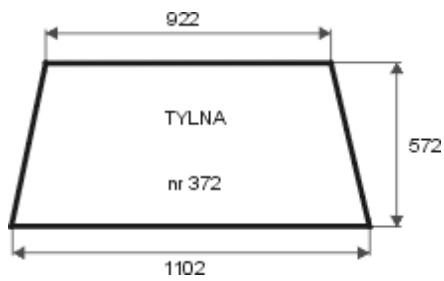
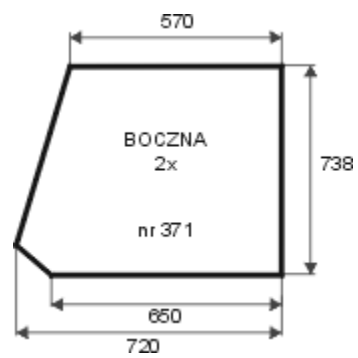
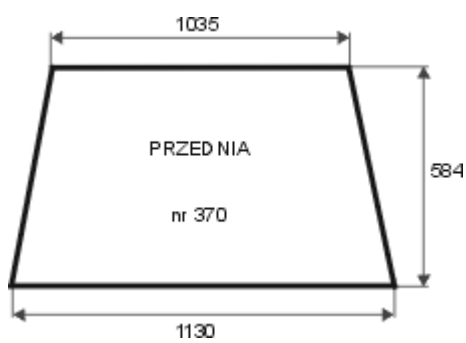

MF 225 - 235

bez boków

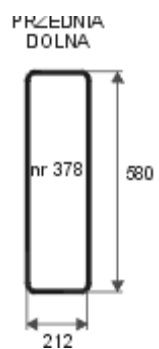
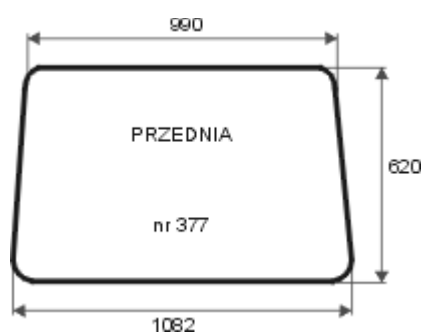

MF - 255

Symbol standard 31976 K91

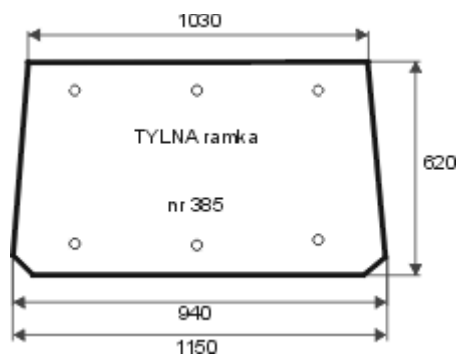
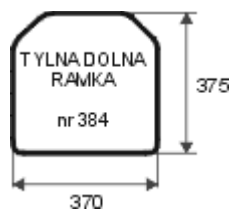
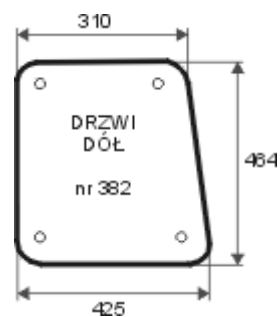
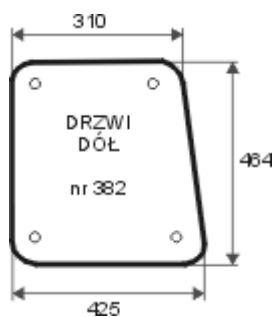
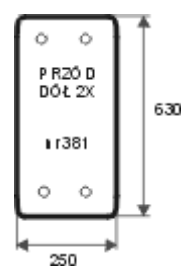
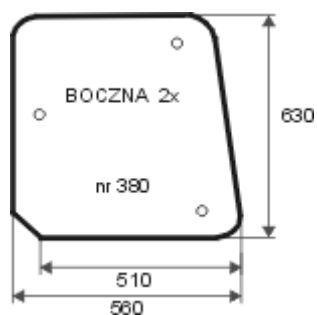
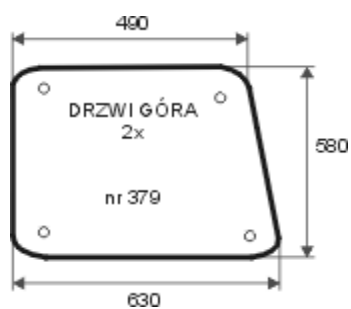

MF - 255 Chetmża



Mała Grzywna

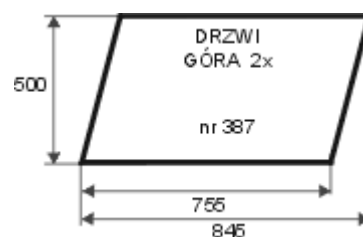
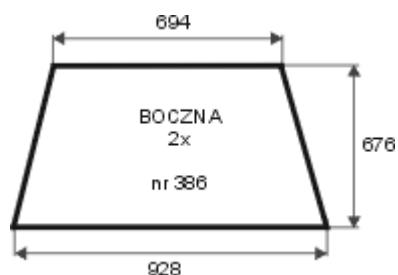

PRZÓD DÓŁ PRAWY



PRZÓD DÓŁ LEWY

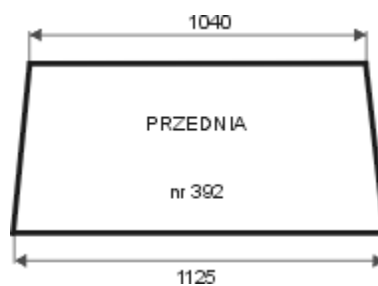
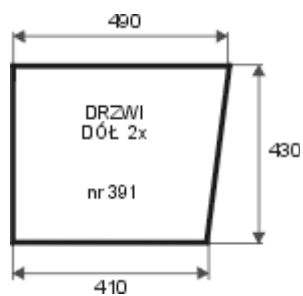
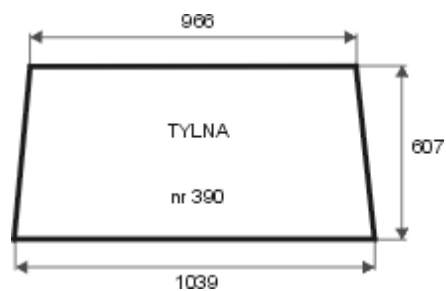
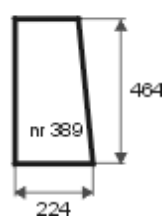

Kabina mała do MF 255

Produkowana w Krotoszynie

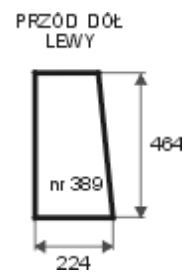
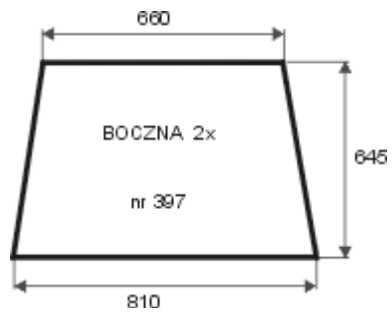
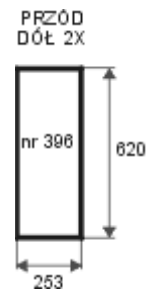
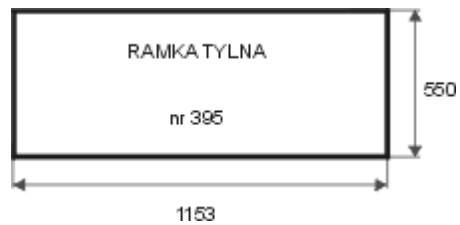
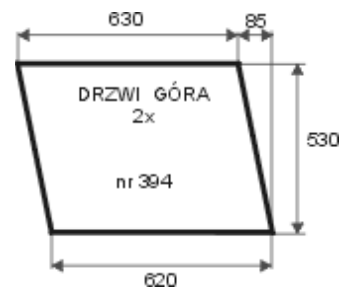
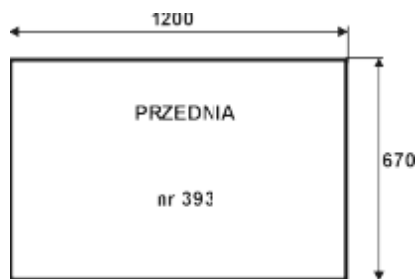

Kabina duża do MF - 255

Produkowana w Krotoszynie

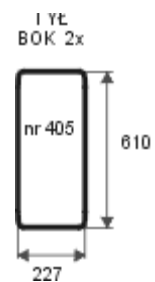
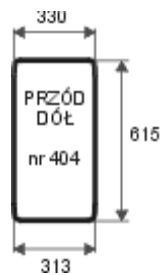
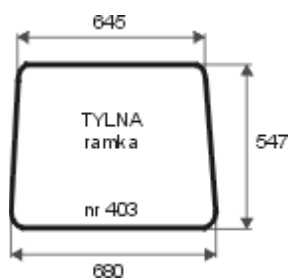
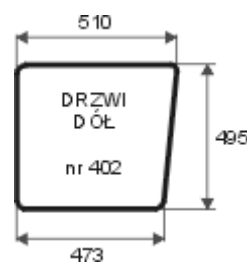
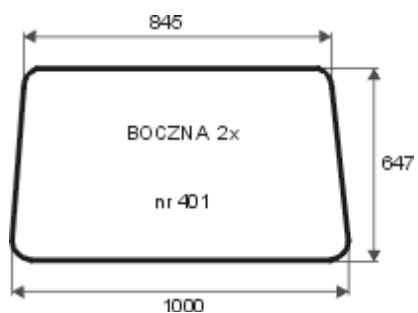
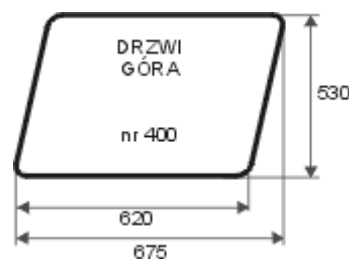
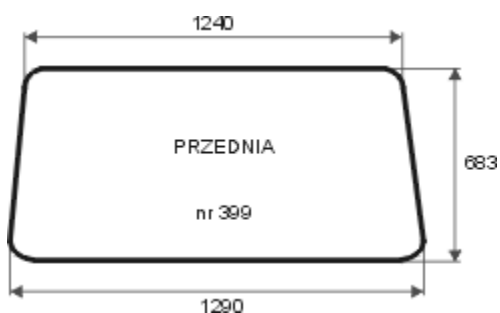

MF 255 Lubsko typ KBMF/1

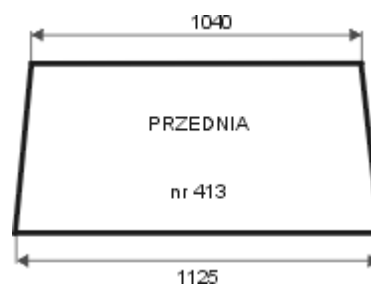
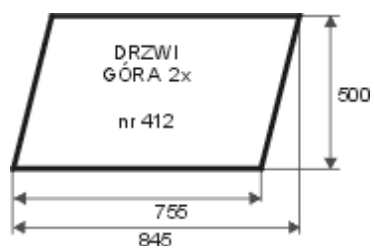
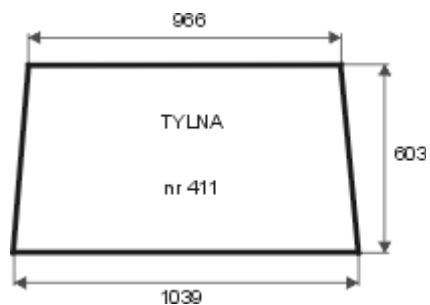
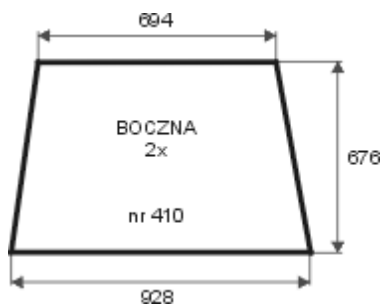
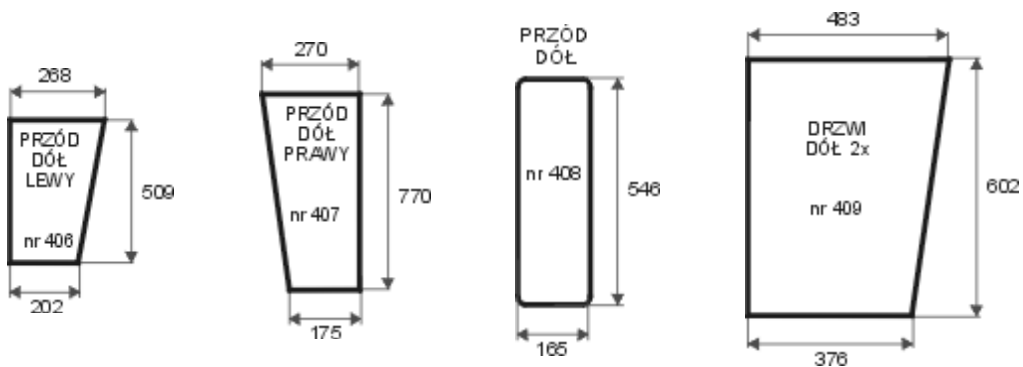

MF 255 Lubsko

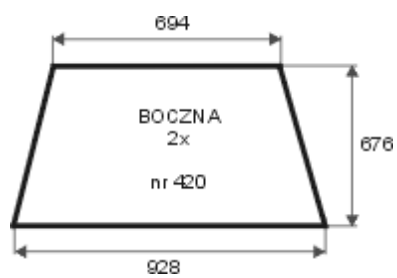
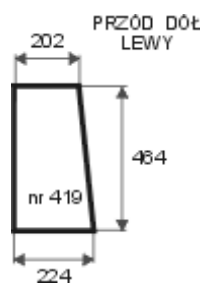
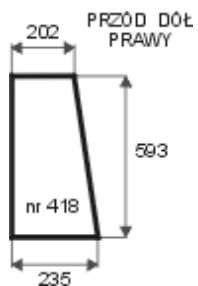
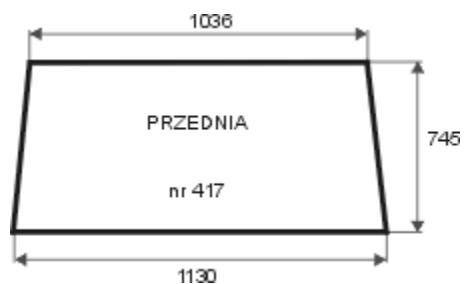
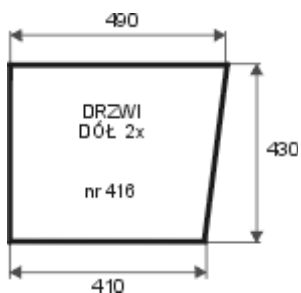
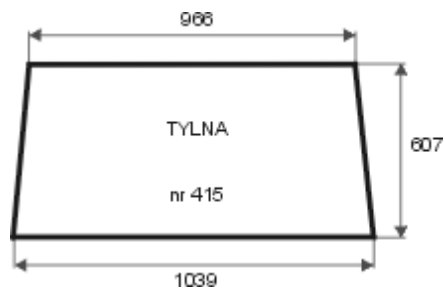
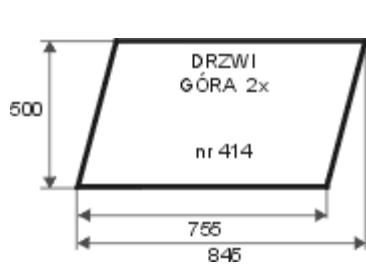

MF 255 Lubsko

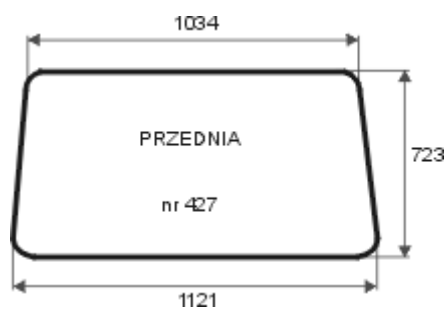
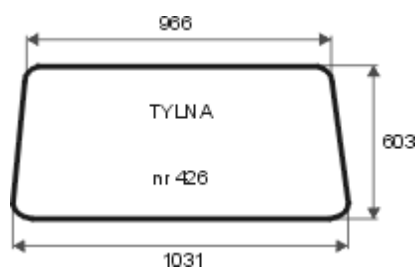
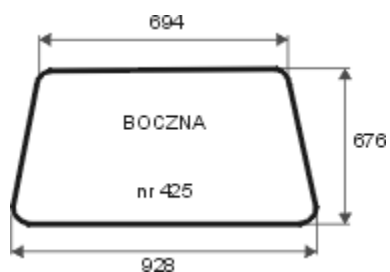
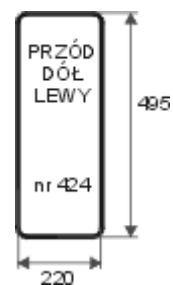
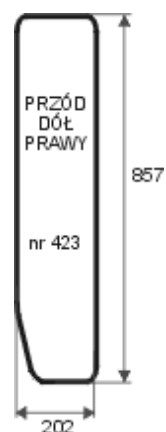
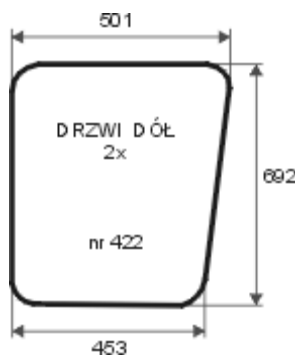
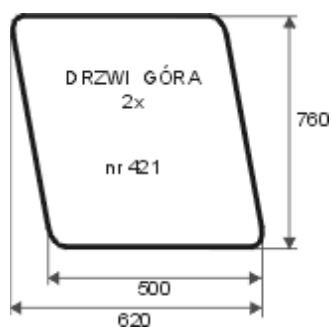

MF - 255 POM Zamość

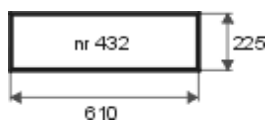
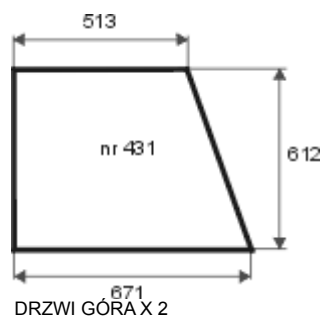
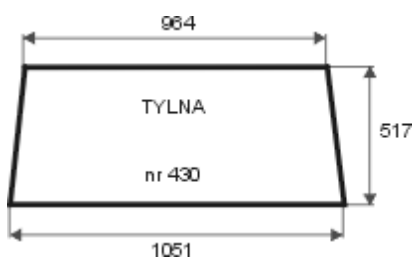
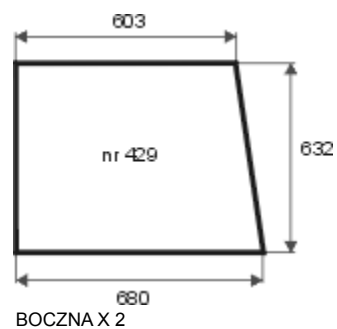
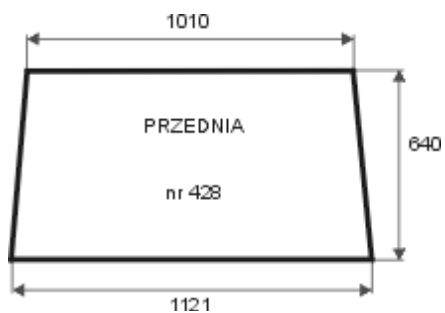

PRZEDNIA DOLNA X 2

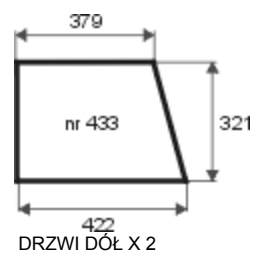

MF 255 POM Zamość

(nowy typ) rok produkcji 1996

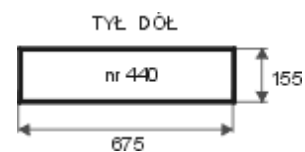
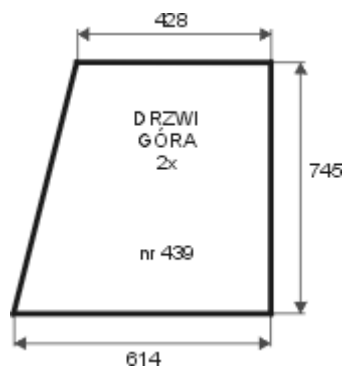
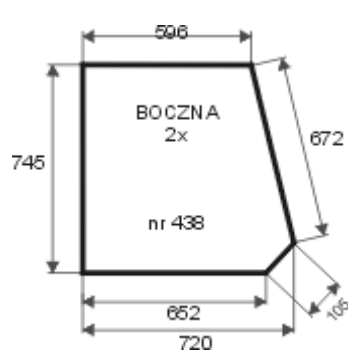
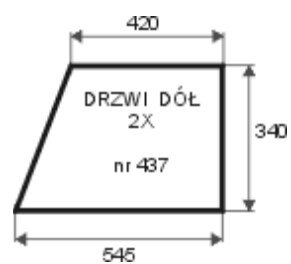
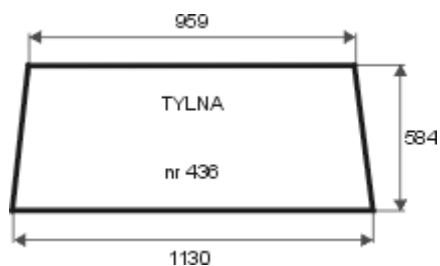
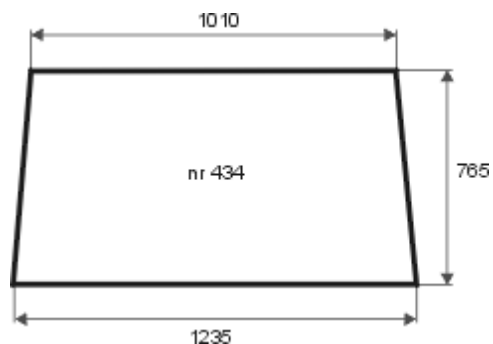

MF - 255 Sokółka

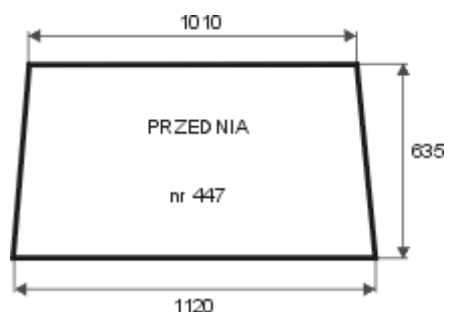
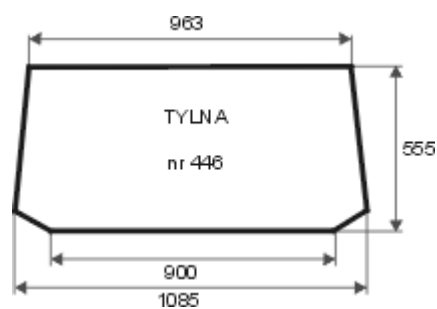
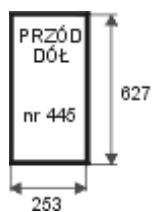
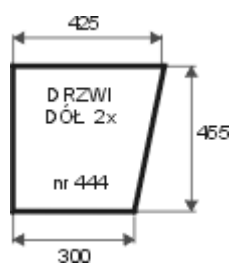
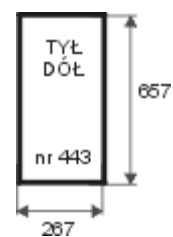
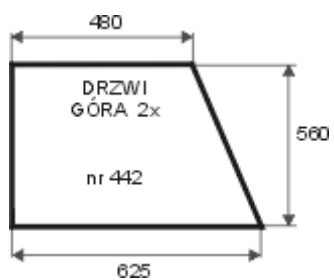

MF - 255 Sokółka K-403

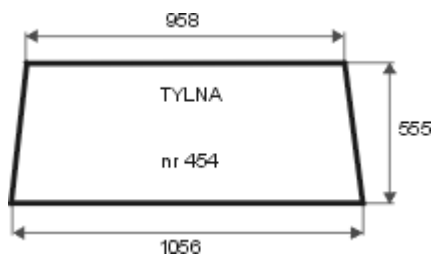
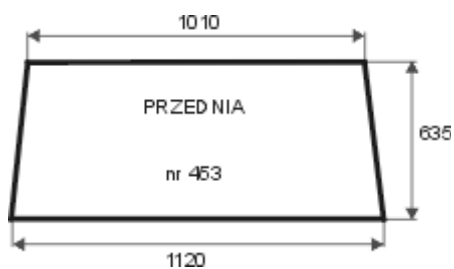
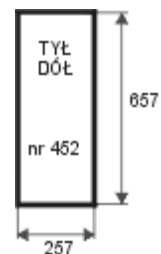
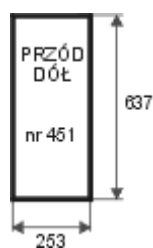
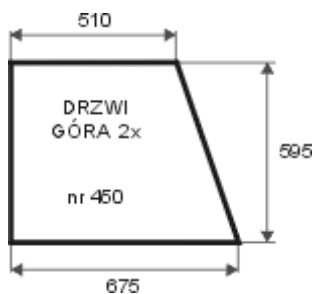
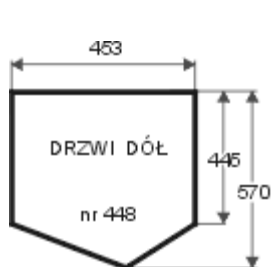

MTZ - 82

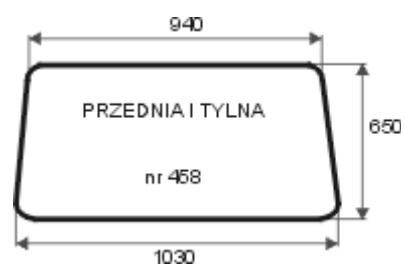
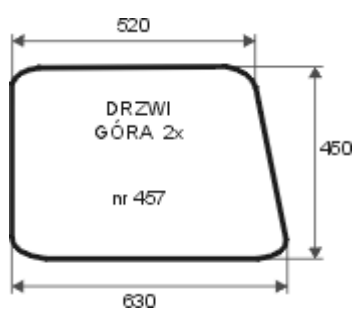
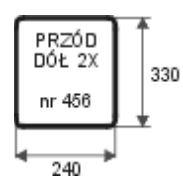
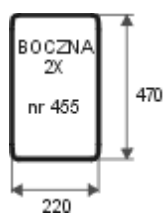

MTZ - 82

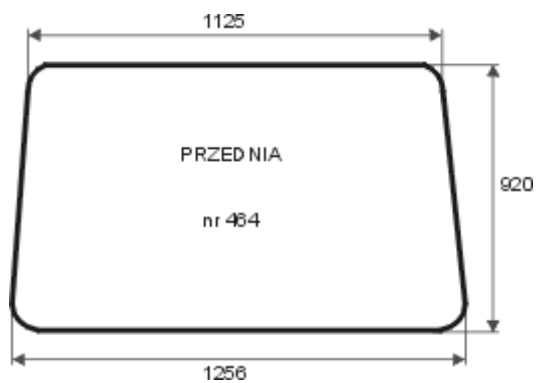
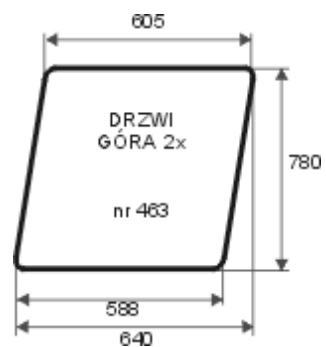
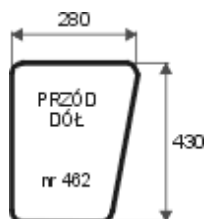
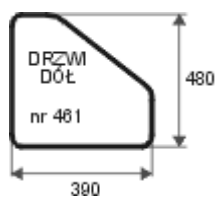
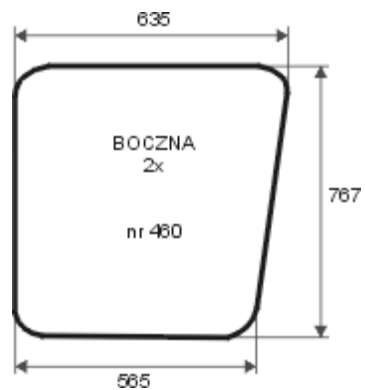
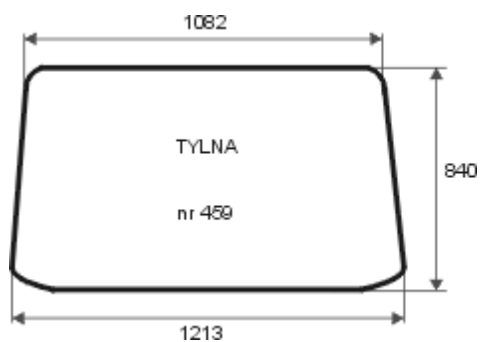

T - 25 A2

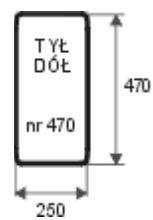
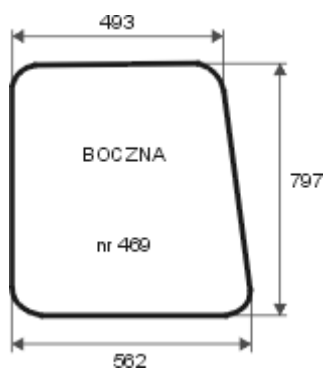
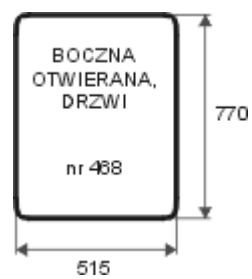
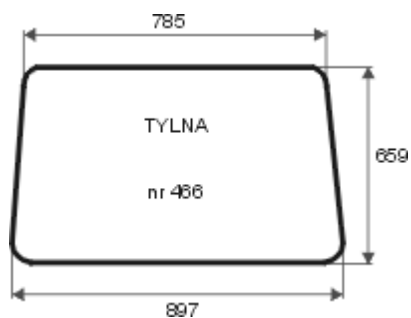
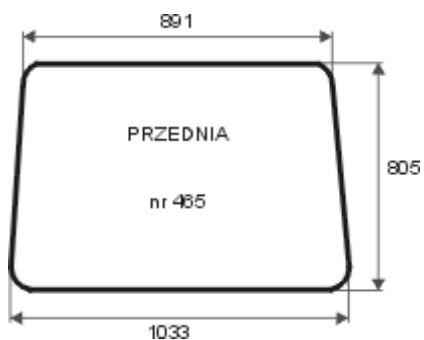

T 25 A2 Ciechanów

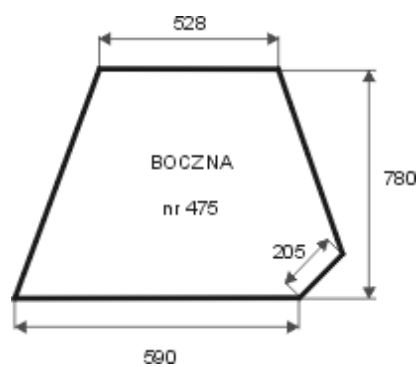
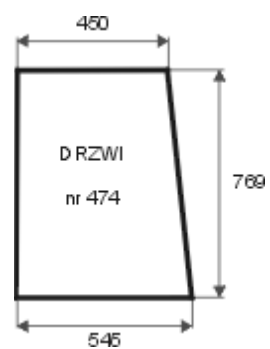
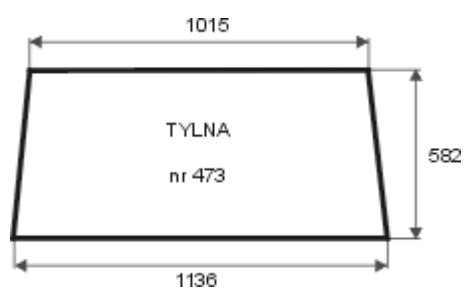
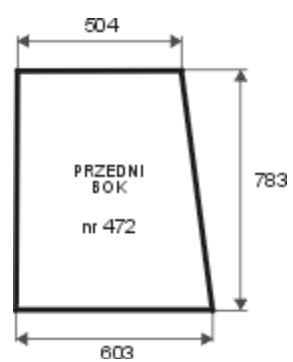
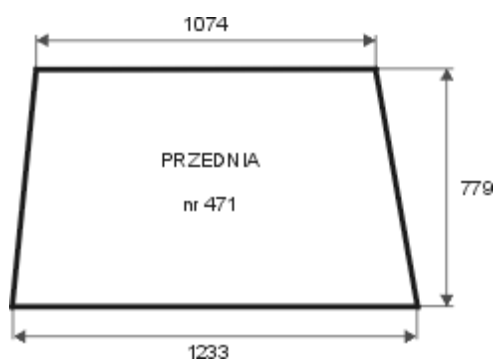

Czeska kabina ciągnik T-25 a

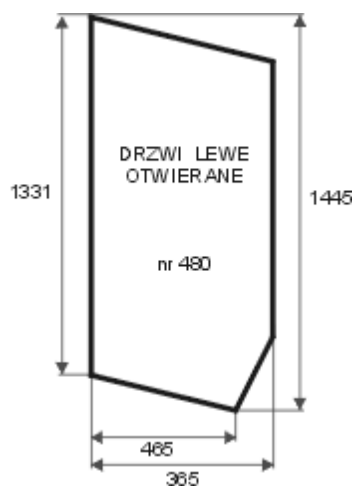
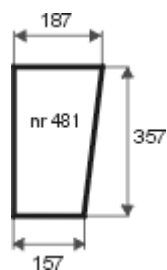
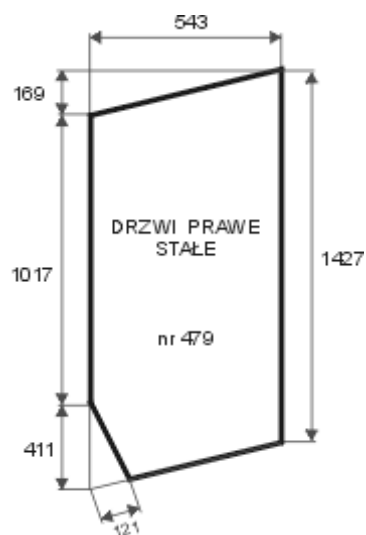
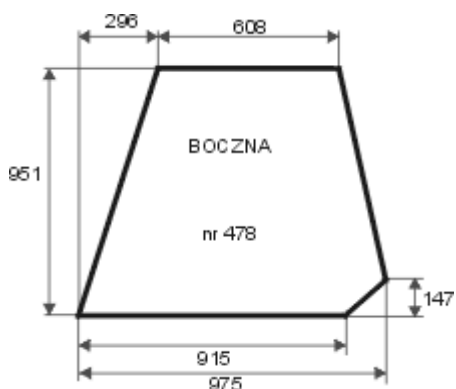
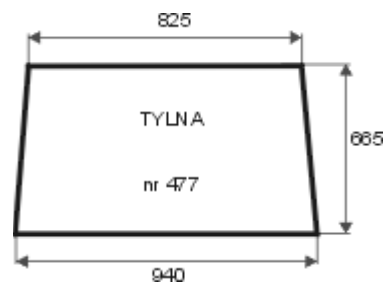
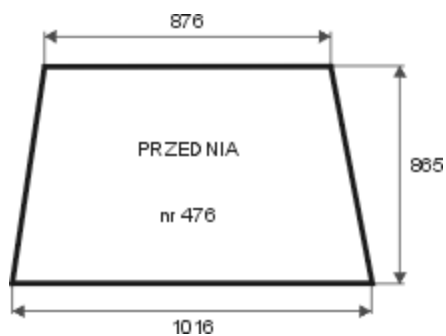

T 25 A Smolniki

(kabina firmy Koja)

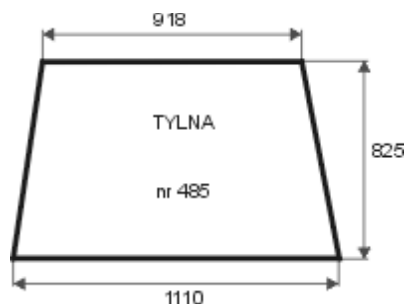
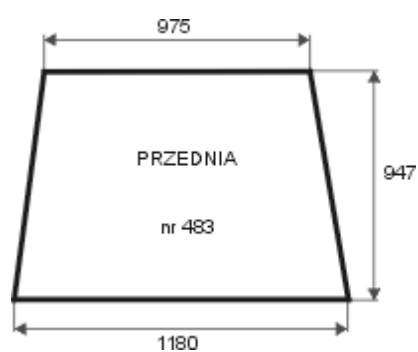
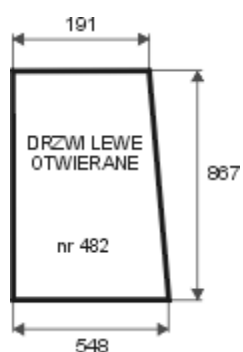

T 25 A2 Sokółka

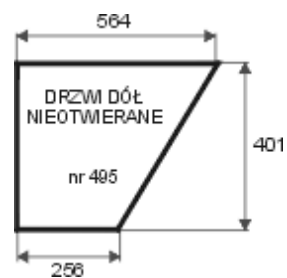
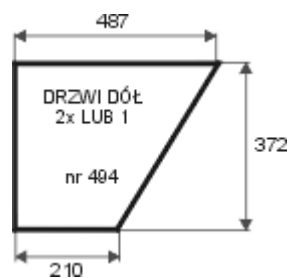
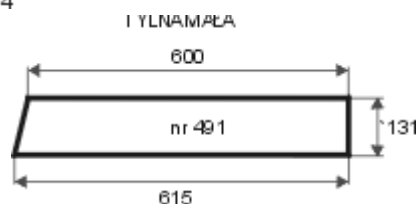
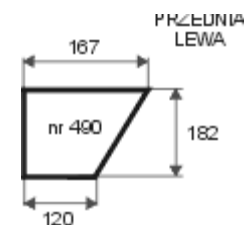
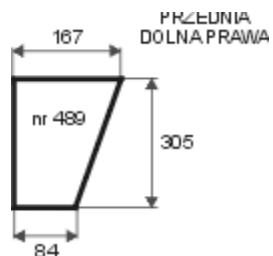
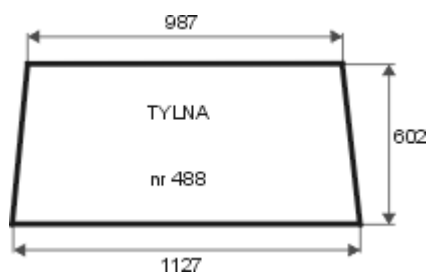
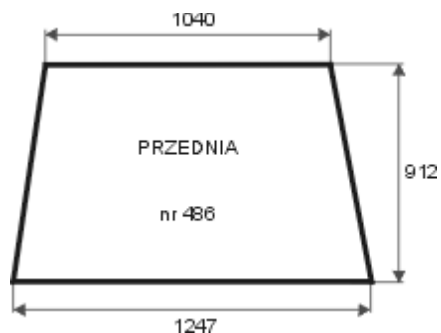

T - 25 Ciechocin

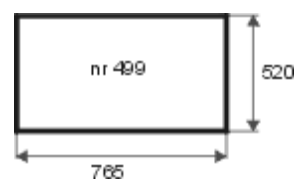
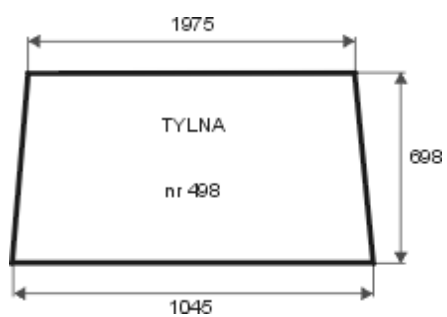
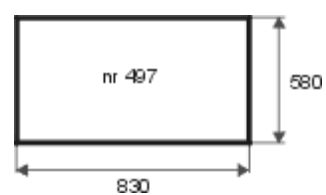
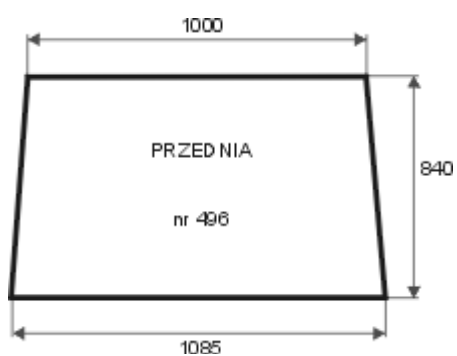

T - 25 POM Zamość

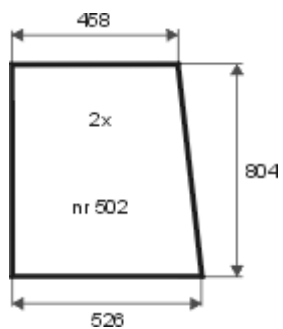
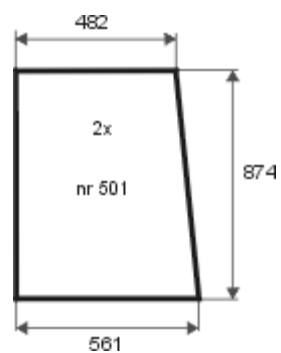
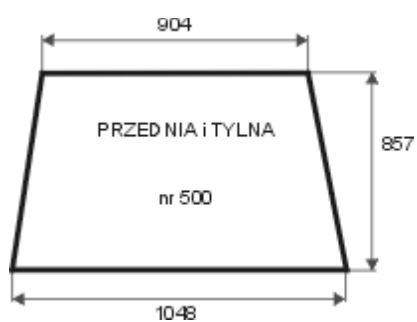

C - 355 Kabina czeska

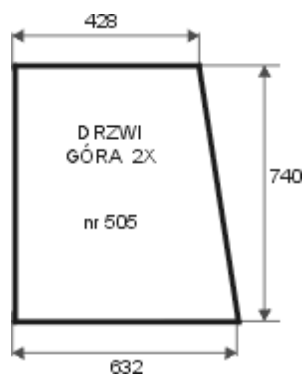
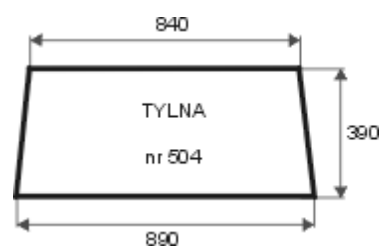
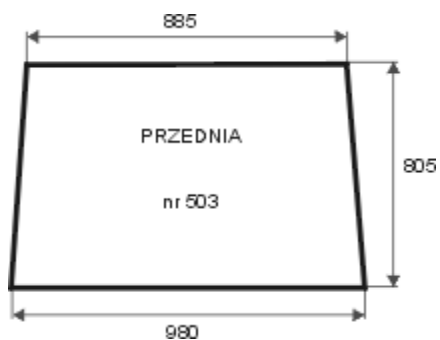

PRZÓD DÓŁ,
PRAWY

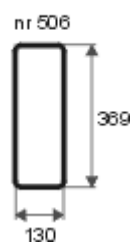

PRZÓD DÓŁ,
LEWY

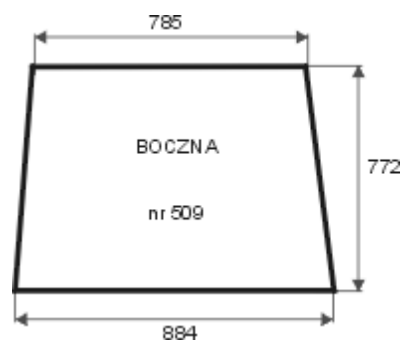
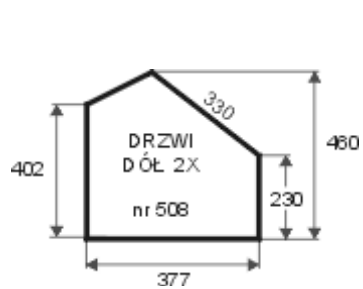
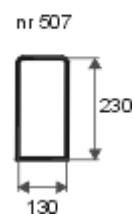

Kabina do ciągnika C - 362

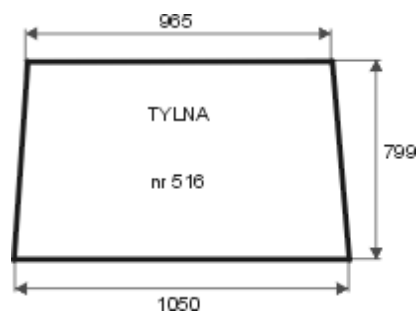
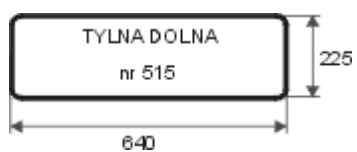
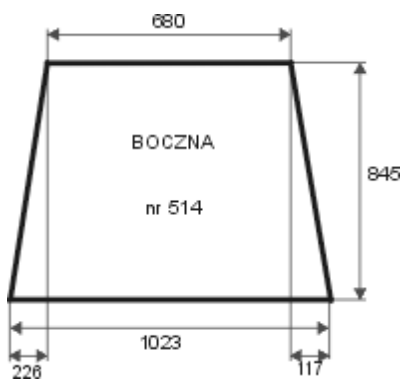
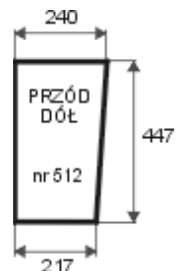
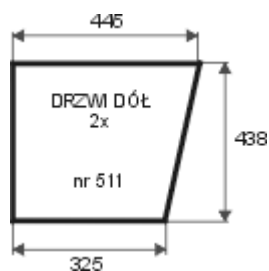
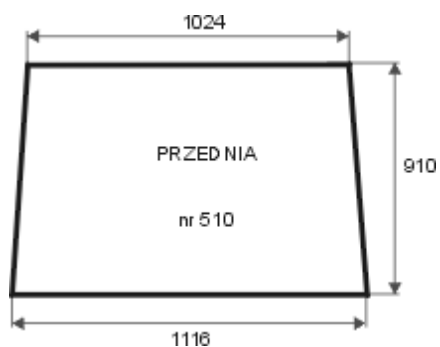

Kabina z Koźmina

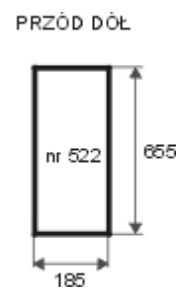
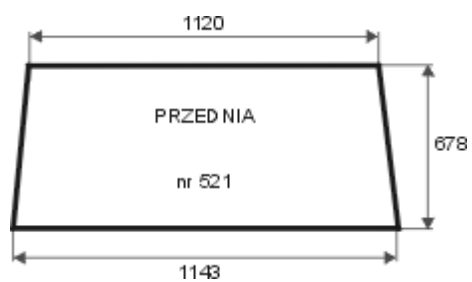
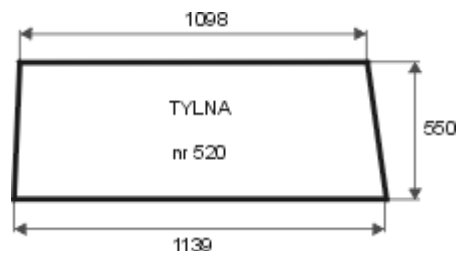
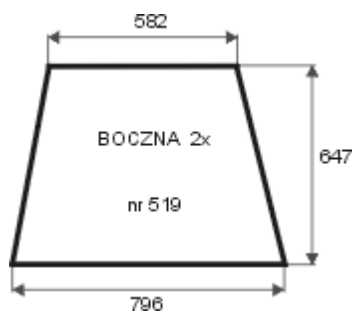
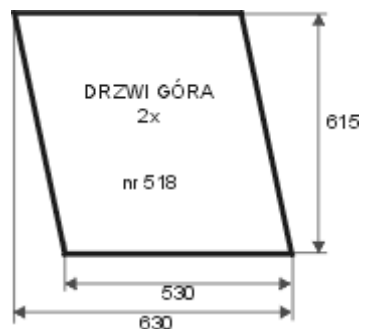
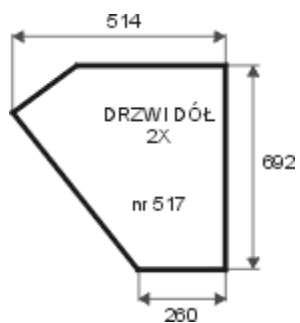

Kabina z Lubania k. Poznania

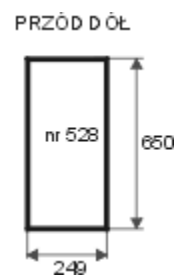
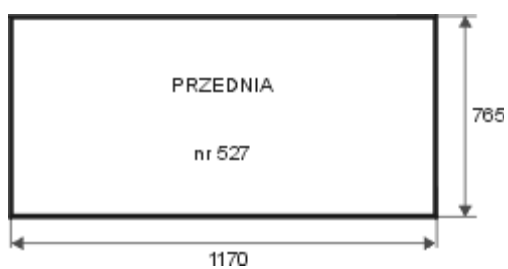
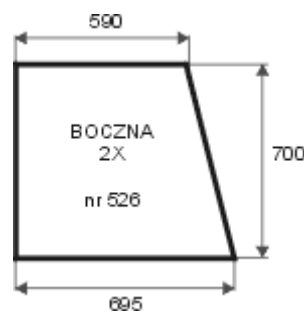
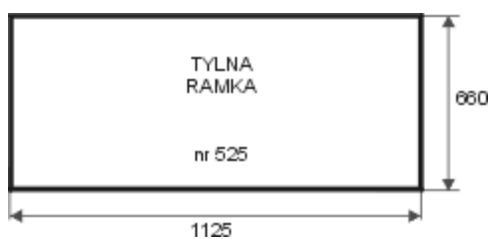
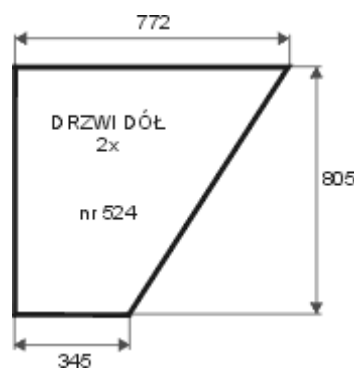
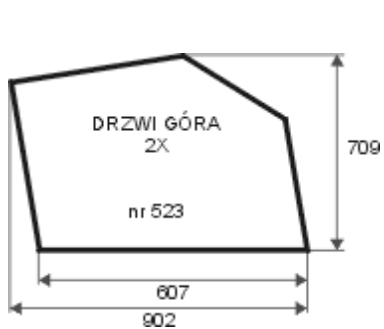

Farm - Mott 250 D

Smolniki Koja

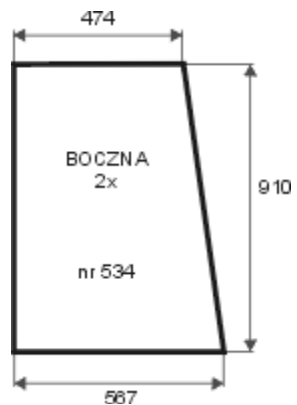
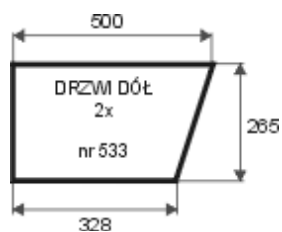
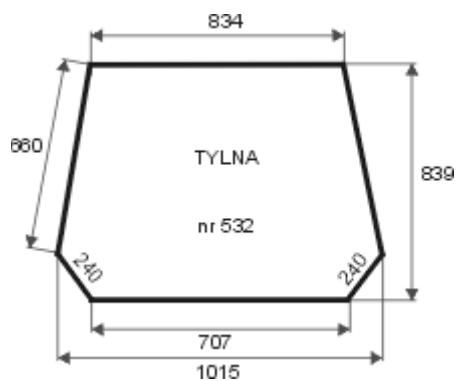
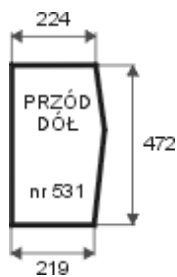
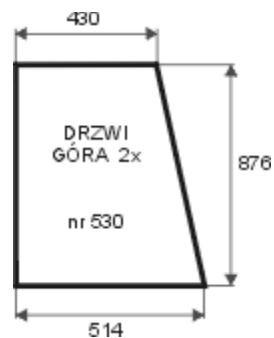
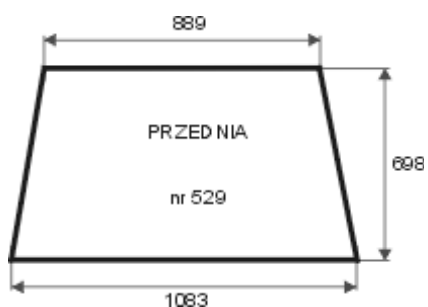

Kombajn BIZON

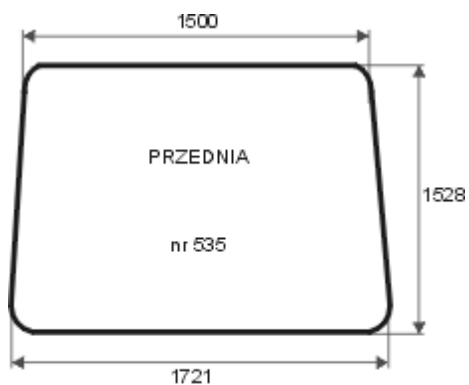

562

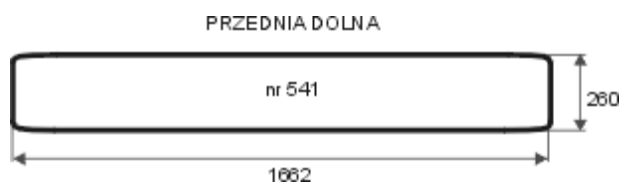
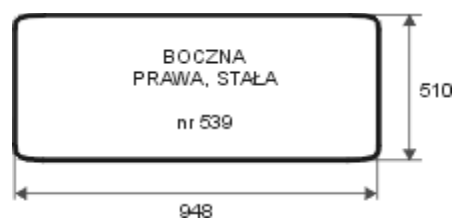
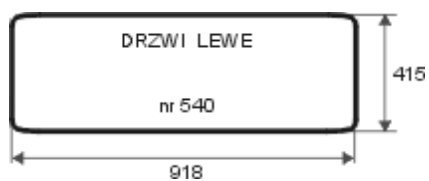

Kombajn BIZON - REKORD 58

